



University of
Nottingham
UK | CHINA | MALAYSIA

Seals

Static sealing

Sealing rotating shafts

Sealing reciprocating shafts

Dr Hengan Ou

Coates B80a

h.ou@nottingham.ac.uk

Learning Objectives

- To be able to identify a number of different types of sealing devices
- To be able to select a suitable seal for static, rotating or reciprocating condition
- To be able to determine groove dimensions of “O” ring using British Standards via NUsearch and select a radial lip seal via seal manufacturer’s catalogue (e.g. SKF, James Walker)
- To be able to estimate the leakage flow through a labyrinth seal

Types of Seals

Part 1:

- **Static Sealing**
 - General principles of fluid sealing
 - **'O' rings**
 - Gaskets

Part 2:

- **Seals for Rotating Applications**
 - Low pressure & cold condition incl **radial lip seal**
 - High pressure
 - Hot condition

Part 3:

- **Seals for Reciprocating Applications**
 - Hot conditions, fast movement
 - Hot conditions, slow movement
- **Worked examples**
 - **"O" ring** selection via **BSI** (British Standard Institution)
 - **Radial lip seal** selection via **SKF** (a bearings & seals manufacturer)

Functions

- **Seals** are devices used to prevent or limit leakage of fluids or particulates.

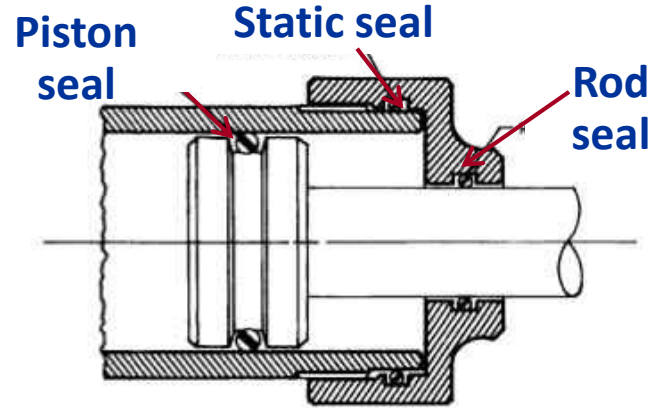

'O' ring used for static & reciprocating sealing

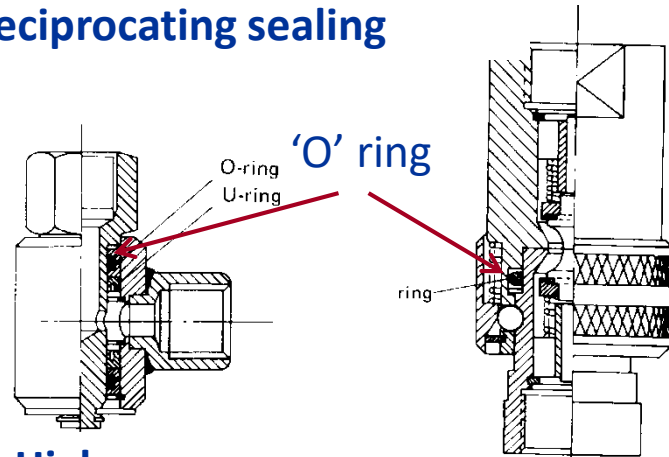

High pressure swivel coupling

type of high pressure flexible hose which uses an O-ring.

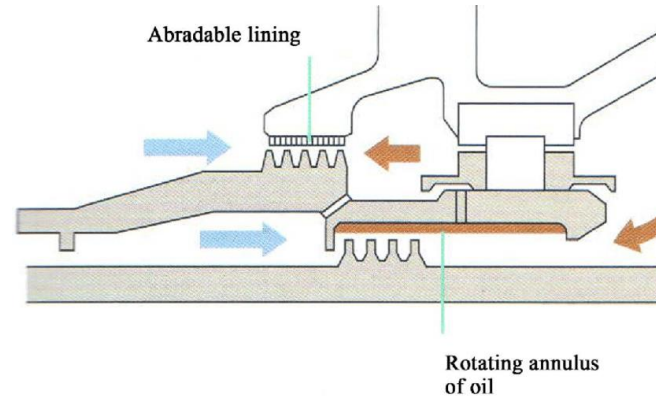

Sealing air Oil Rotating assemblies

Labyrinth seal for high speed and high temperature condition

High pressure flexible hose

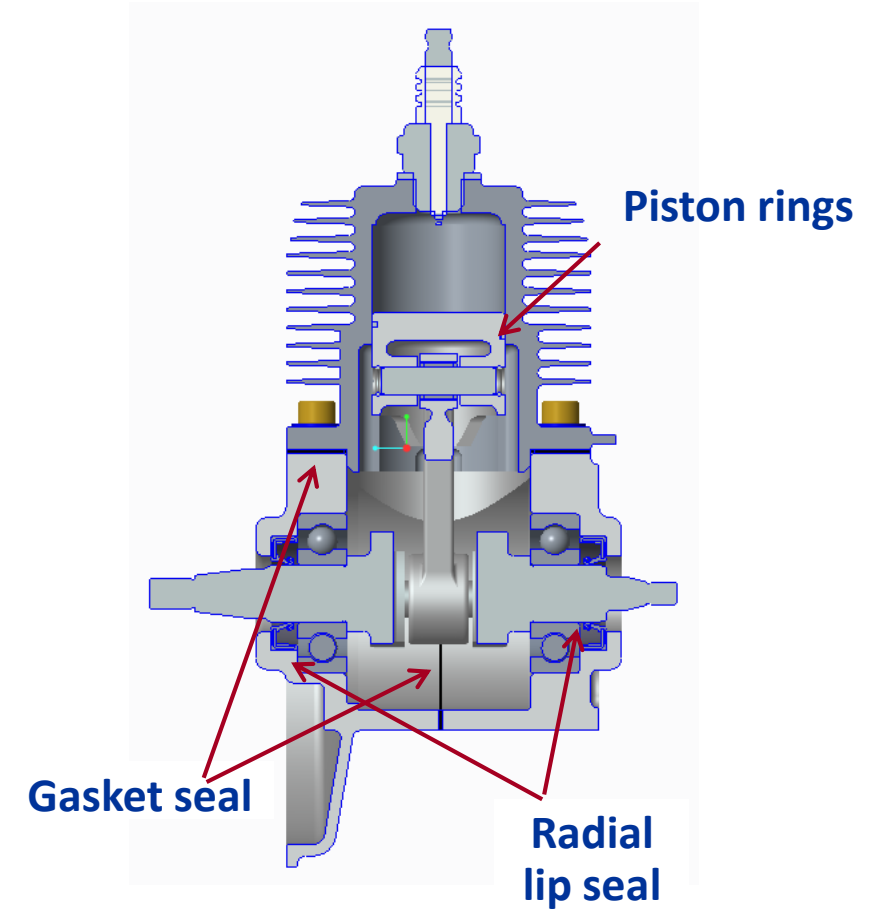

2-stroke engine

Classification of seals

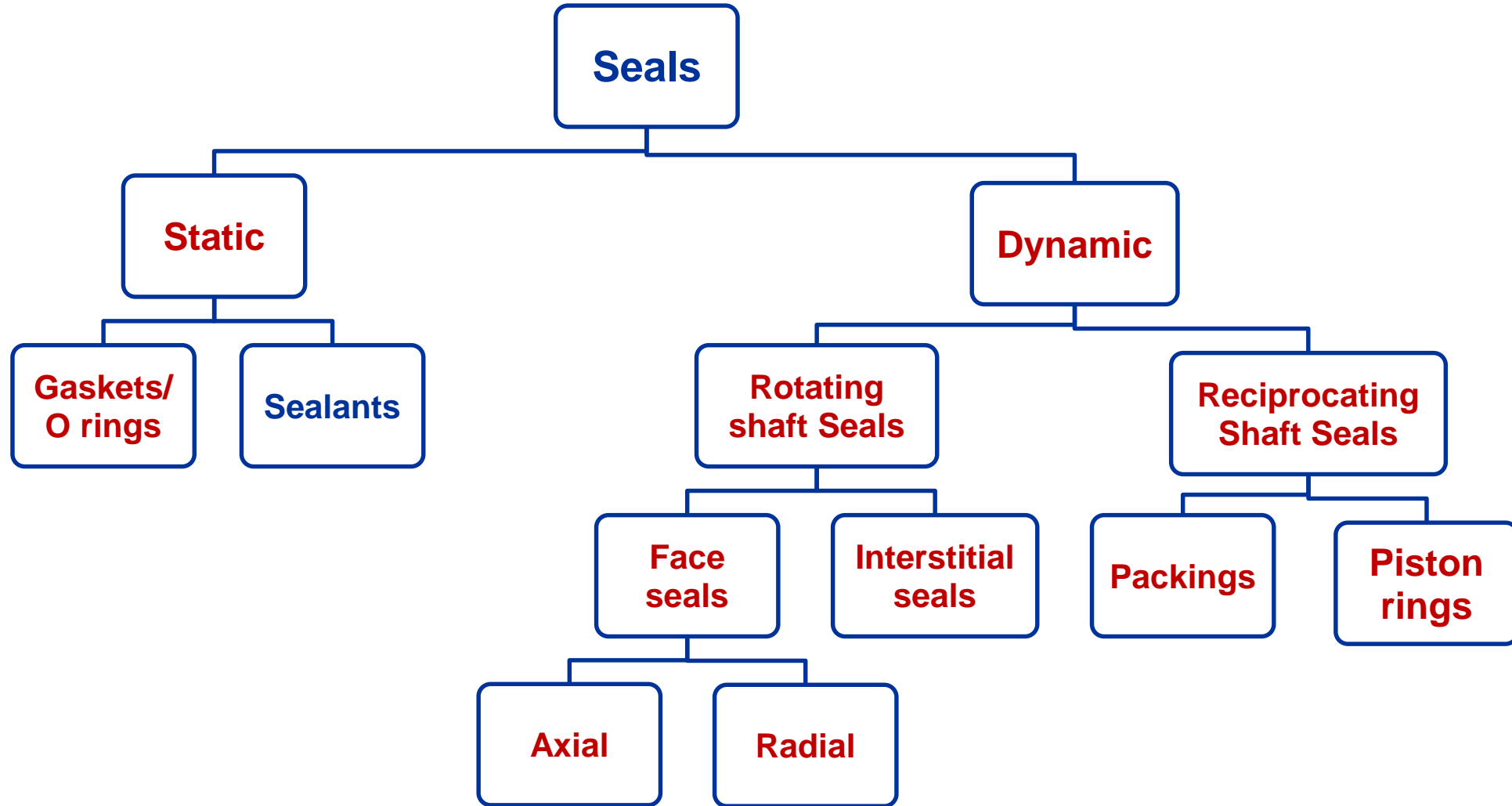

Selection and design considerations

What do Seals do?

- Keep fluid in
- Keep dirt out
- Allow motion:
 - linear
 - rotational
- Allow disassembly

How do they do it?

- Physical barrier
- Tortuous path

What are the design considerations?

- Fluids, grease or compressed air
- Pressures
- Temperatures
- Motions
 - linear
 - rotational
 - speeds
- Cost/Fabricability
- Longevity
- Level of sealing

'O' Rings – static & slow motion

- “Toroidal”, “elastomeric”
- Simple & versatile for static and low-speed application
- Requiring an **interference fit** with one of the mating parts
- Application is codified – use a standard where possible (e.g. **BS 4518:1982**)

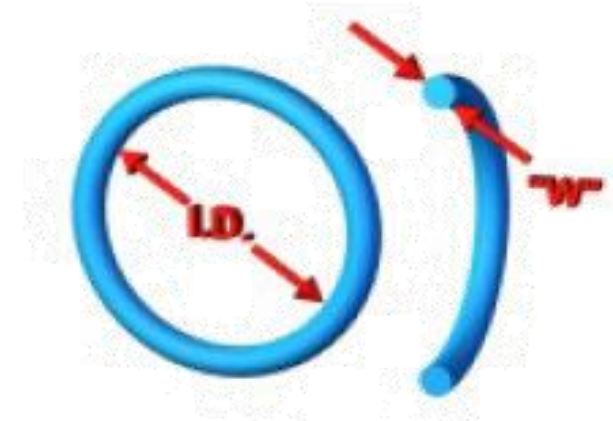

Note: **BS ISO 3601-1~5** defines another set of “O” ring details.

- Sized by **internal diameter (ID)** & **section diameter (A)**

'O' Ring Sealing Mechanism

- Incompressible rubber get the **SQUEEZE** through correct groove dimensions;
- Pre-compression ensures sealing when no pressure;
- When pressure is applied the ring is forced against gap and seals it.

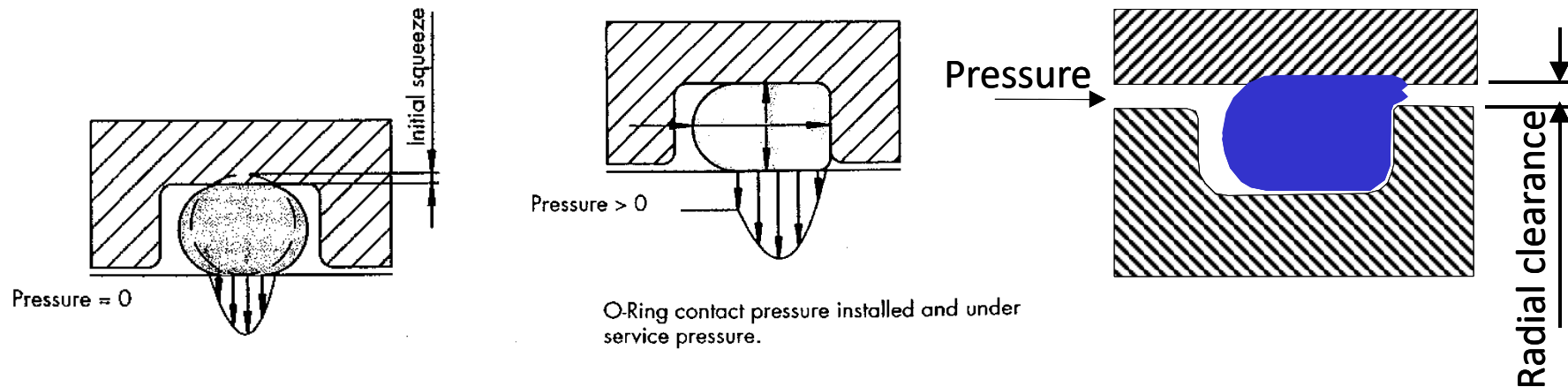

O-Ring contact pressure installed and under service pressure.

Too big clearance can lead to 'extrusion' failure

Challenger space shuttle disaster

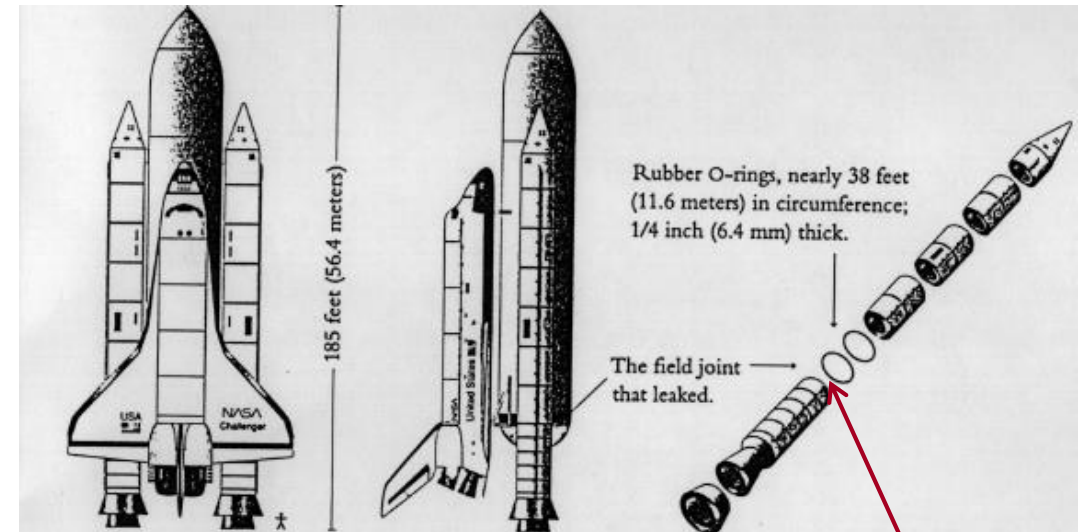

Failed O-Rings of **solid rocket booster**, which is made of sections

28th Jan 1986, Space Shuttle Challenger broke apart 73 seconds into its flight, leading to the deaths of its seven crew members

Detail of seal

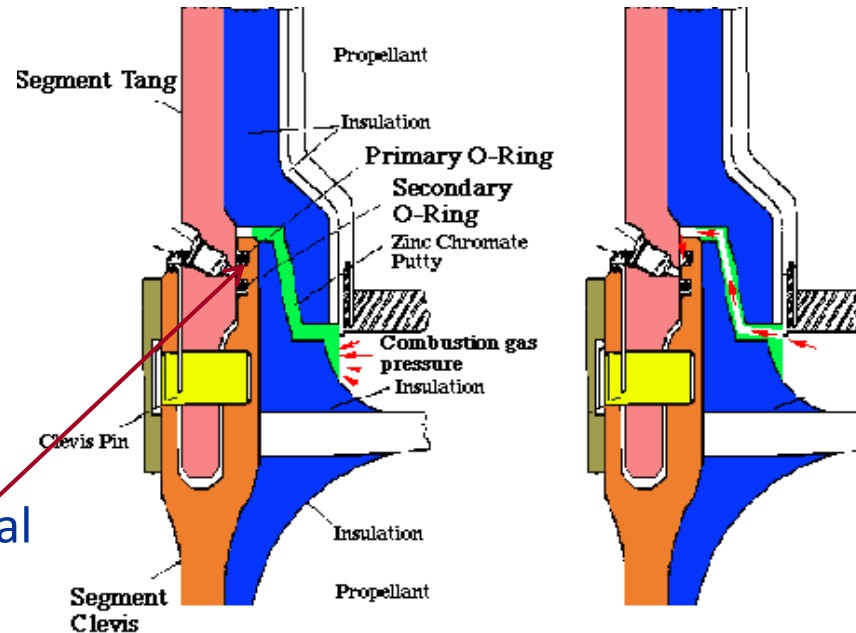

[https://en.wikipedia.org/wiki/Space_Shuttle Challenger disaster](https://en.wikipedia.org/wiki/Space_Shuttle_Challenger_disaster)

Case study of Challenger Space Shuttle Disaster

Disaster

What went wrong?

- At low temperatures, O-rings lost their resilience;
- Booster cases distorted greatly during launch;
- **Insufficient groove width in O-ring design.**

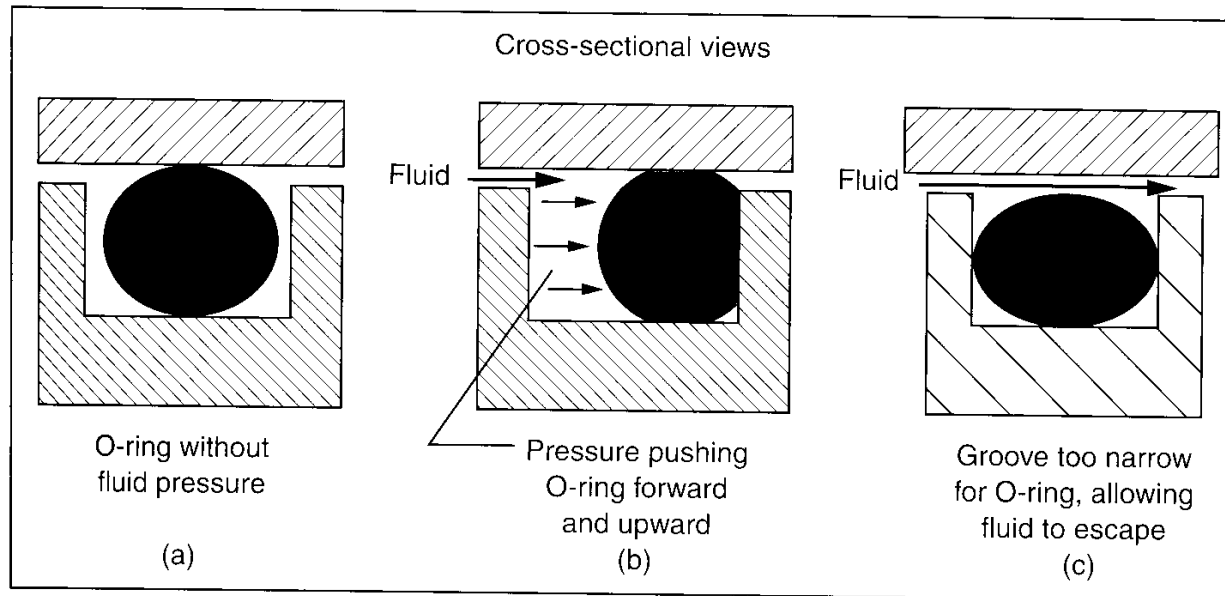

FIGURE 4.15 (a) O-ring in groove; (b) O-ring acting as a seal under pressure; (c) O-ring placed in a groove of insufficient width, leading to leakage of the fluid. *Source:* Adapted from Kamm, 1991.

Common Forms of Failure

- **Abrasion**: sealing face is worn away.
- **Solution**:
 - Smoother surface to $0.4\mu\text{m Ra}$;
 - Harder 'O' ring material;
 - Better lubricant;
 - Reduced speed.
- **Compression set**: the sealing face is permanently distorted.
- **Solution**:
 - Higher temperature-resistant 'O' ring.



Abrasion



Compression set

Common Forms of Failure

- **Installation damage:** Damaged during installation.
- **Solution:**
 - Chamfer & blending radii.



Installation damage

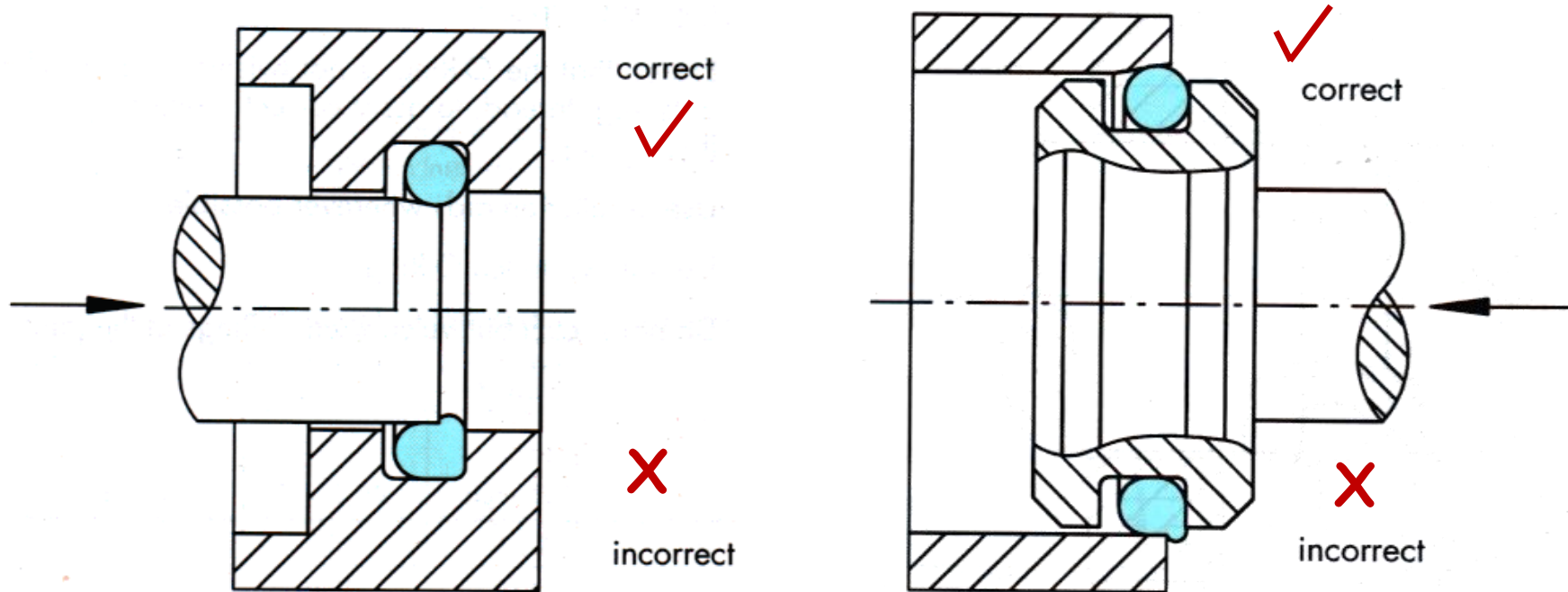

Common forms of Failure

- **Extrusion**: the 'O' ring is forced into the sealing clearance.
- **Solution**:
 - Smaller clearances < 0.13 mm;
 - Harder material;
 - Different cross section of ring;
 - Use Backup Ring;
 - Backup rings from a range of shapes & sizes (**BS 5106:1988**).

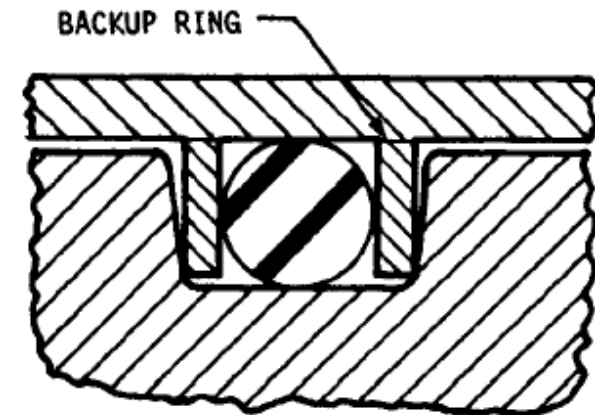

Backup rings



solid



Spiral



split

Common forms of Failure

- **Spiral damage:** 'O' ring is twisted and leaks.
- **Solution:**
 - Lower reciprocating speed;
 - Harder material;
 - Different cross section of ring – e.g. quadrant seal,
 - “Nu-lip” or “Quad” rings having a roughly square or X-shaped section.



Spiral damage

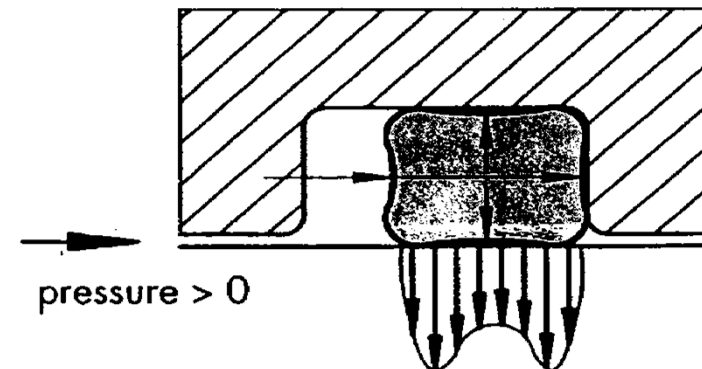
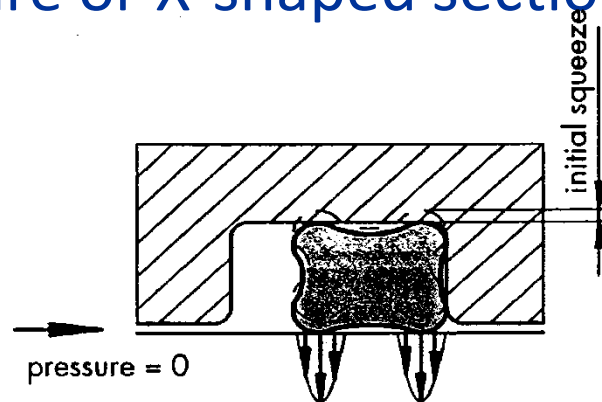

'O' Ring dimensions Example

(BS 4518:1982+A2:2014)

Determine "O" ring 0121-16 dimensions

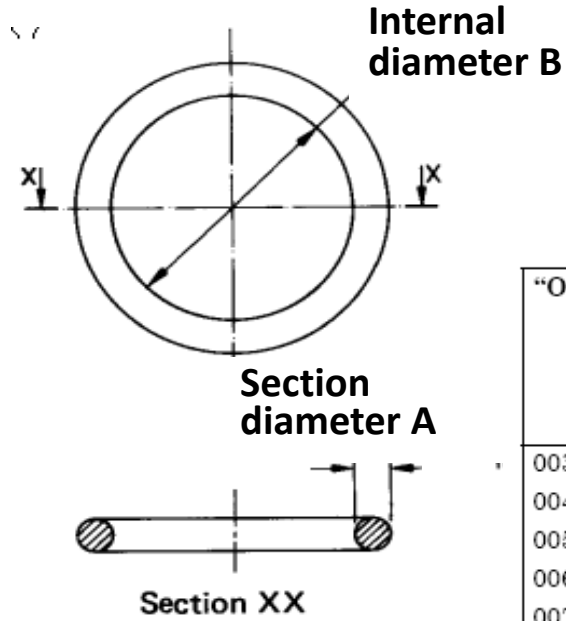

Table 1 — Dimensions of "O"-rings (see Figure 1) and related nominal housing diameters for diametral sealing (see Figure 2)

All dimensions in millimetres

| "O"-ring ref. no (see note) | "O"-ring dimensions | | | | Nominal housing dimensions (see Figure 2 and 4.1) | |
|--------------------------------|---------------------|-----------------------------|--------------------|----------------------------|------------------------------------------------------|-------------------------|
| | Internal diameter B | Internal diameter tolerance | Section diameter A | Section diameter tolerance | Shaft diameter d_1 | Cylinder diameter D_1 |
| 0031-16 | 3.1 | ± 0.15 | 1.6 | | 3.5 | 6 |
| 0041-16 | 4.1 | | 1.6 | | 7.5 | 10 ^a |
| 0051-16 | 5.1 | | 1.6 | | 8.5 | 11 |
| 0061-16 | 6.1 | | 1.6 | | 9.5 | 12 ^b |
| 0071-16 | 7.1 | | 1.6 | | 10.5 | 13 |
| 0081-16 | 8.1 | | 1.6 | | 11.5 | 14 |
| 0091-16 | 9.1 | | 1.6 | | 12.5 | 15 |
| 0101-16 | 10.1 | ± 0.2 | 1.6 | ± 0.08 | 13.5 | 16 ^b |
| 0111-16 | 11.1 | | 1.6 | | 14.5 | 17 |
| 0121-16 | 12.1 | | 1.6 | | 15.5 | 18 |
| 0131-16 | 13.1 | | 1.6 | | 16.5 | 19 |
| 0141-16 | 14.1 | | 1.6 | | 17.5 | 20 ^b |
| 0151-16 | 15.1 | | 1.6 | | | |
| 0161-16 | 16.1 | | 1.6 | | | |
| 0171-16 | 17.1 | | 1.6 | | | |

$d_1 = \phi 12.5$ mm (groove in cylinder)
 $D_1 = \phi 15$ mm (groove in piston)

0121-16

$B = \phi 12.1$ mm
 $A = \phi 1.6$ mm

Static/dynamic diametral sealing, hydraulic & pneumatic

From BS 4518:1982

Example

Seals Part 1

Table 2 — Groove dimensions for static diametral sealing (see Figure 2) (mm)
Static sealing All dimensions in millimetres

| "O"-ring ref. no. | Cross section diameter A | Radial depth F | | Groove width $E^{+0.2}_0$ | Total diametral clearance G (max.) | Lead-in chamfer C | Max. radius R |
|--------------------|--------------------------|----------------|------|---------------------------|------------------------------------|-------------------|---------------|
| | | max. | min. | | | | |
| 0031-16 to 0371-16 | 1.6 | 1.25 | 1.18 | 2.3 | 0.12 | 0.6 | 0.5 |
| 0036-24 to 0896-24 | 2.4 | 1.57 | 1.84 | 3.1 | 0.14 | 0.7 | 0.5 |
| 0195-30 to 2495-30 | 3.0 | 2.50 | 2.35 | 3.7 | 0.15 | 0.8 | 1.0 |
| 0443-57 to 4993-57 | 5.7 | 4.95 | 4.70 | 6.4 | 0.18 | 1.2 | 1.0 |
| 1441-84 to 2491-84 | 8.4 | 7.50 | 7.20 | 9.0 | 0.20 | 1.5 | 1.0 |

Table 3 — Groove dimensions for dynamic diametral sealing in hydraulic applications (see Figure 2)

Dynamic: hydraulic All dimensions in millimetres

| "O"-ring ref. no. | Cross section diameter A | Radial depth F | | Groove width $E^{+0.2}_0$ | Total diametral clearance G (max.) | Lead-in chamfer C | Max. radius R |
|--------------------|--------------------------|----------------|------|---------------------------|------------------------------------|-------------------|---------------|
| | | max. | min. | | | | |
| 0036-24 to 0176-24 | 2.4 | 2.09 | 1.97 | 3.2 | 0.14 | 0.6 | 0.5 |
| 0195-30 to 0445-30 | 3.0 | 2.65 | 2.50 | 4.0 | 0.15 | 0.7 | 1.0 |
| 0443-57 to 1443-57 | 5.7 | 5.18 | 4.95 | 7.5 | 0.18 | 1.0 | 1.0 |
| 1441-84 to 2491-84 | 8.4 | 7.75 | 7.50 | 11.0 | 0.20 | 1.2 | 1.0 |

Table 4 — Groove dimensions for dynamic diametral sealing in pneumatic applications (see Figure 2)

Dynamic: pneumatic All dimensions in millimetres

| "O"-ring ref. no. | Cross section diameter A | Radial depth F | | Groove width $E^{+0.2}_0$ | Total diametral clearance G (max.) | Lead-in chamfer C | Max. radius R |
|--------------------|--------------------------|----------------|------|---------------------------|------------------------------------|-------------------|---------------|
| | | max. | min. | | | | |
| 0036-24 to 0176-24 | 2.4 | 2.20 | 2.13 | 3.2 | 0.14 | 0.6 | 0.5 |
| 0195-30 to 0445-30 | 3.0 | 2.77 | 2.70 | 4.0 | 0.15 | 0.7 | 1.0 |
| 0443-57 to 1443-57 | 5.7 | 5.38 | 5.22 | 7.5 | 0.18 | 1.0 | 1.0 |
| 1441-84 to 2491-84 | 8.4 | 7.96 | 7.75 | 11.0 | 0.20 | 1.2 | 1.0 |

Determine suitable groove in cylinder for an **0221-16** for static sealing

Groove in cylinder dimensions

$F_{\max} = 1.25$
 $F_{\min} = 1.18$
 $E^{+0.2} = 2.3$
 $G = 0.12$
 $C = 0.6$
 $R = 0.5$

Material Compatibility

| Material | Hardness (Shore A) | Temps (°C) | Uses |
|-------------------------|-----------------------|---------------|-----------------------------------------------------------------|
| Nitrile rubber | 70 | -30 ~ +110 | General purpose: fuel, oils, water, hydraulic fluid |
| Silicone | 70 | -60 ~ +200 | Medical – body fluid resistant, low temp, alcohol, oxygen |
| Viton (fluorocarbon) | 85 | -20 ~ +200 | High temperature, extreme chemicals |
| Polyurethane | 95 | -30 ~ +110 | High temps, oil, gas and hydraulics resistant, good wear |

Shore A hardness

Rubber band 20

Pencil eraser 40

Tire tread 70

Shoe heel 80

Other Static Seals - Gaskets

- A material or combination of materials clamped between two separable members to form a joint.
- Its function is to affect a seal between members (flanges) and maintain the seal for a prolonged period.

- Must be:
 - Impervious & resistant to the medium;
 - Withstand the application of temperatures.

Gasket seal

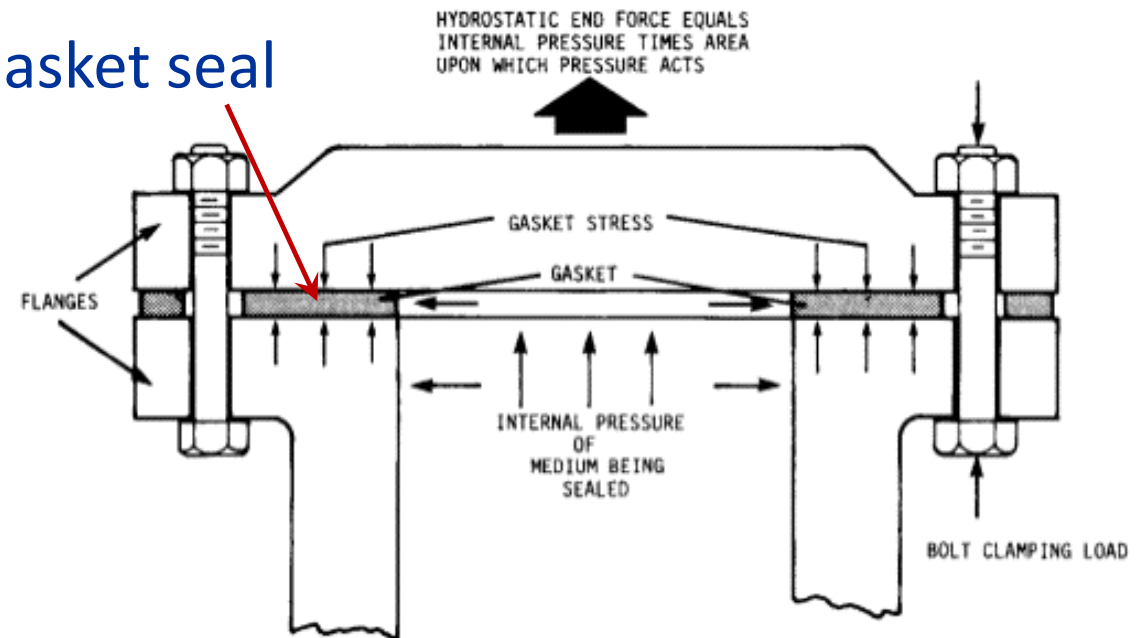

A gasket joint

Gasket Anatomy

1. Base material: compliant element - cork, cellulose fibre, asbestos or non-asbestos fibre)
2. Binders: temperature and chemical resistance – rubber, elastomeric, resins
3. Fillers: fill voids in the base material – rubber, elastomeric, resins
4. Reinforcements: prevent distortion – metal or fabric core

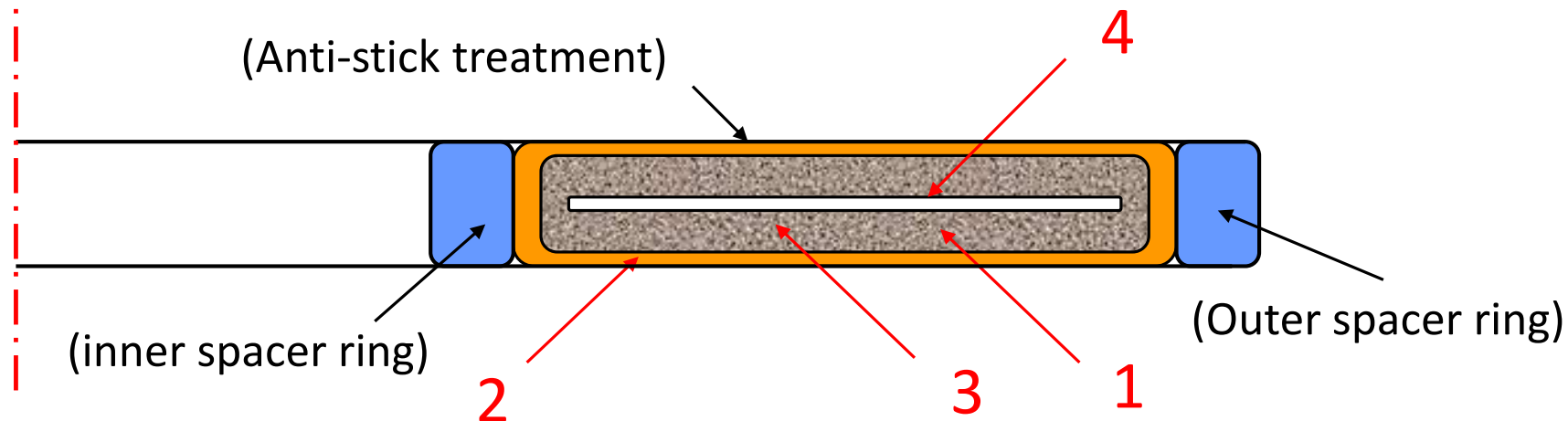

Quiz 1: BS4518:1982 "O" rings

What are the **internal diameter (ID)** and **section diameter (A)** of a **0493-57** "O" ring?

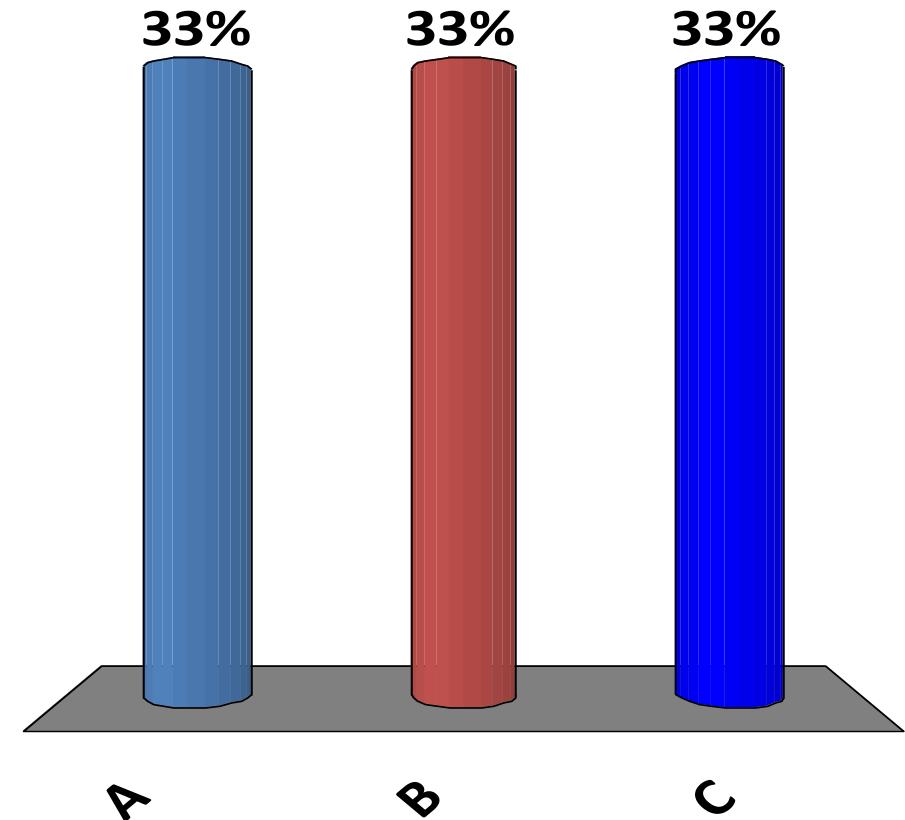

- A. ID = 493 mm and A = 57 mm
- B. ID = 49.3 mm and A = 5.7 mm
- C. ID = 4.93 mm and A = 0.57 mm

B is the correct answer

Worked example 1: “O” ring selection of a pneumatic cylinder

- A pneumatic cylinder has a nominal diameter of $D_1 = \Phi 25 \text{ mm}$. Using **BS4518**, select a suitable “O” ring and determine the groove dimensions in piston and piston diameter.

Seals Part 1

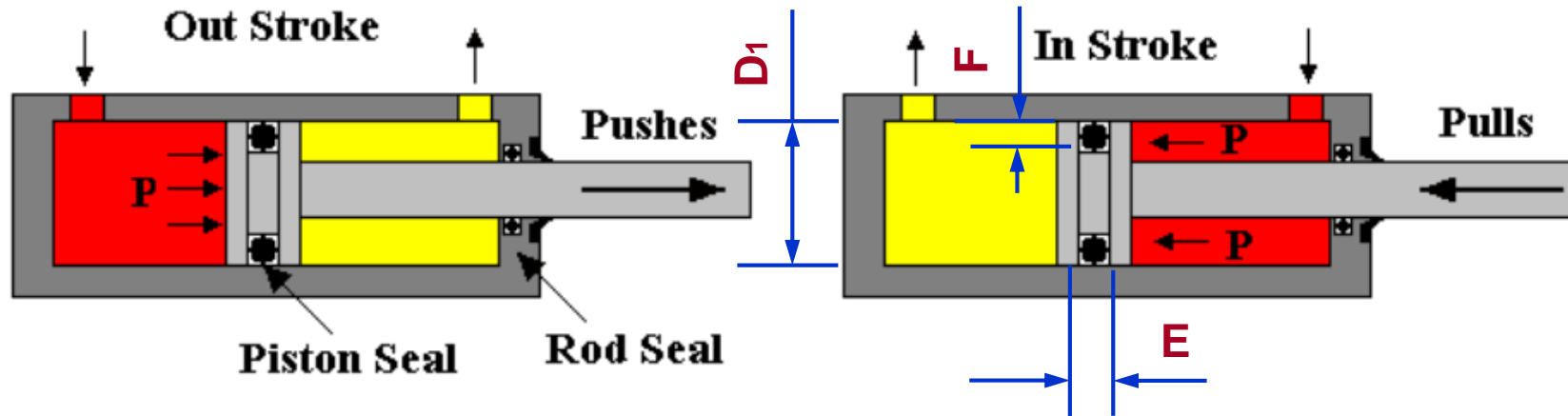

- Key dimensions
 - F – radial depth
 - E – groove width
 - G – total clearance
 - C – lead-in chamfer
 - R – radius
 - D_2 – piston diameter

- NUsearch for BS documents

<https://nusearch.nottingham.ac.uk/>

Worked example 1: "O" ring selection of a pneumatic cylinder

For nominal cylinder dia $D_1 = \Phi 25$ mm, use BS4518

- From Table 1, **0221-16**, **0206-24** and **0195-30** are all suitable to use,
- From Table 4, for **pneumatic** applications, **0195-30** is the only suitable option.

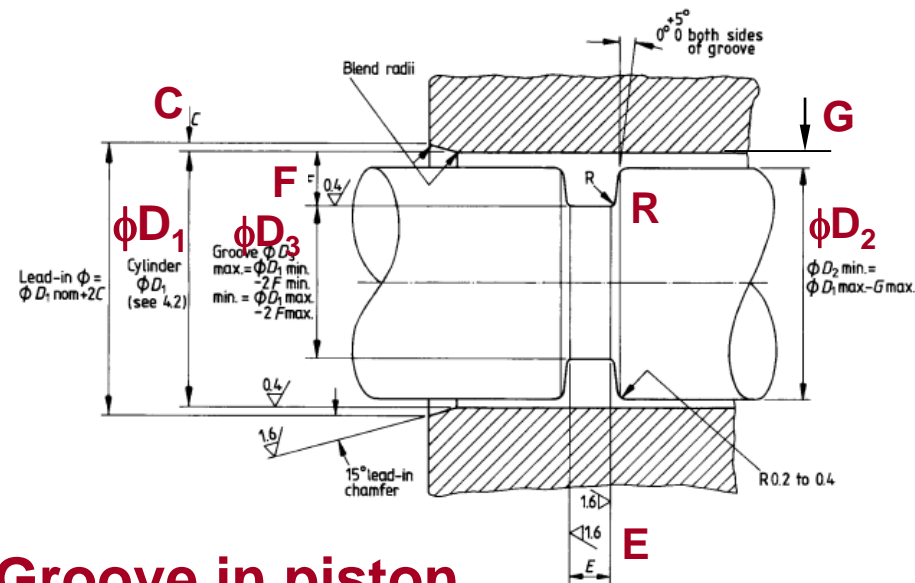
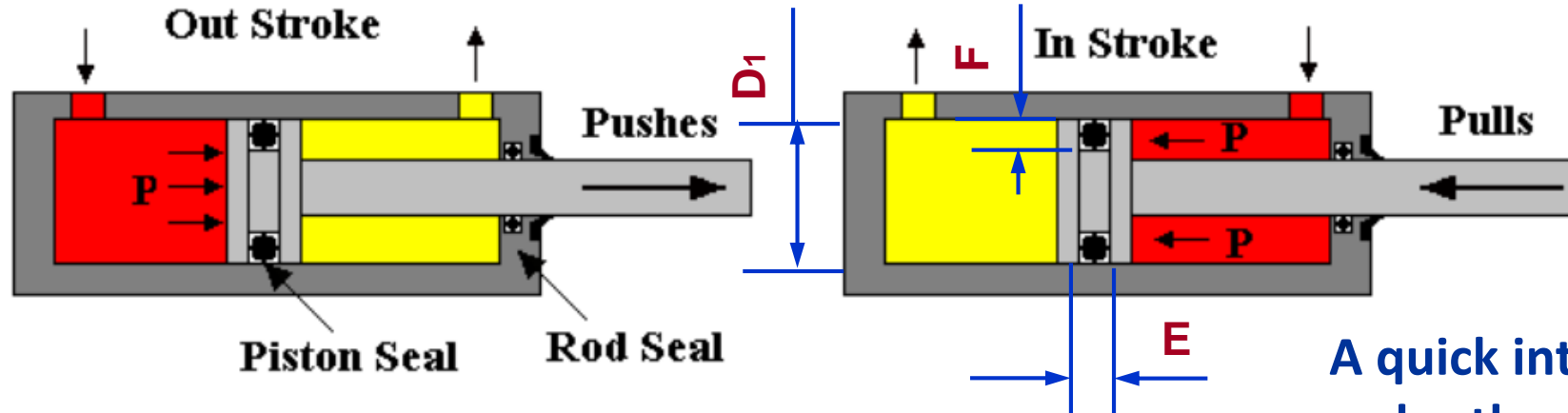

Groove in piston

From Table 4, BS 4518:

Depth $F = 2.70 \sim 2.77$

Width $E = 4.0 + 0.2$

Clearance $G_{max} = 0.15$

Chamfer $C = 0.7$

Radius $R = 1.0$

Piston dia $D_{2min} = 25 - 2 \times 0.15 = \Phi 24.70$

A quick internet search to order the chosen **0195-30**

O-ring from, e.g.

<https://uk.rs-online.com/web/>

or

https://www.jameswalker.biz/en/product_types/39-o-rings



University of
Nottingham

UK | CHINA | MALAYSIA

Seals

End of Part 1



University of
Nottingham

UK | CHINA | MALAYSIA

Seals

Part 2

Sealing rotating shafts

- **Low Pressure & Low Temperature**
 - ‘O’ rings
 - Radial lip seals
 - Axial lip seals
- **High pressure**
 - High performance lip seals
 - Mechanical Seals
- **High Temperature**
 - Labyrinth seals – an example of interstitial seals

'O' Rings

- 'O' rings can be used for in **dynamic** applications
- Friction is high, but sealing is good within their operating range (**up to 14 bar & 3.8 m/s**)
- Surface roughness must not exceed **0.4mm Ra**, though should have some roughness (e.g. **0.1mm Ra**)
- **Spiral and abrasion** are the main failure modes (if installed correctly)

Radial lip seal anatomy

- Low pressure (0.3 – 0.6 bar up to 7 bar with backing plate)
- Moderate speed (up to 16m/s)
- Temperature (up to 100 °C or even higher)
- Normal environmental condition
- Slight leakage permitted
- Normally made of Nitrile rubber compounds

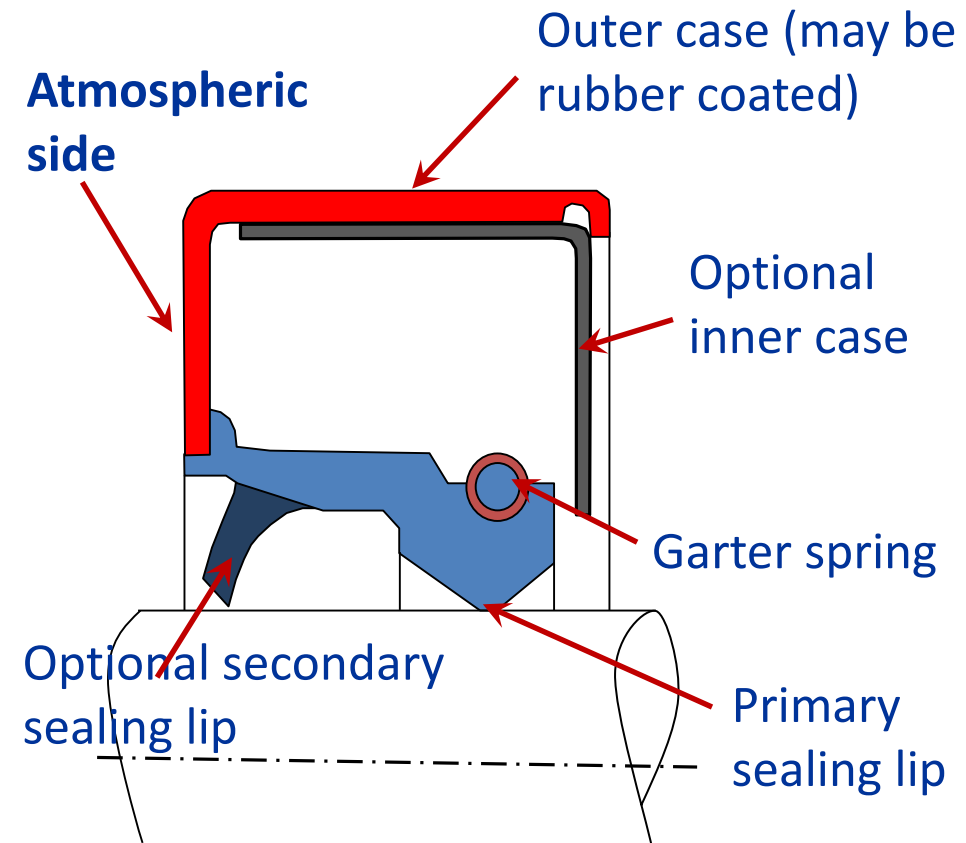
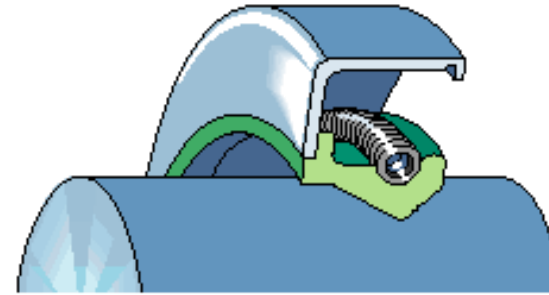

Seals for rotating shafts: low pressure and temperature

- Metal insert lip seal
- Flexible spring loaded sealing lip bears **lightly** onto the shaft sealing surface
- Fluid pressure must act on spring side

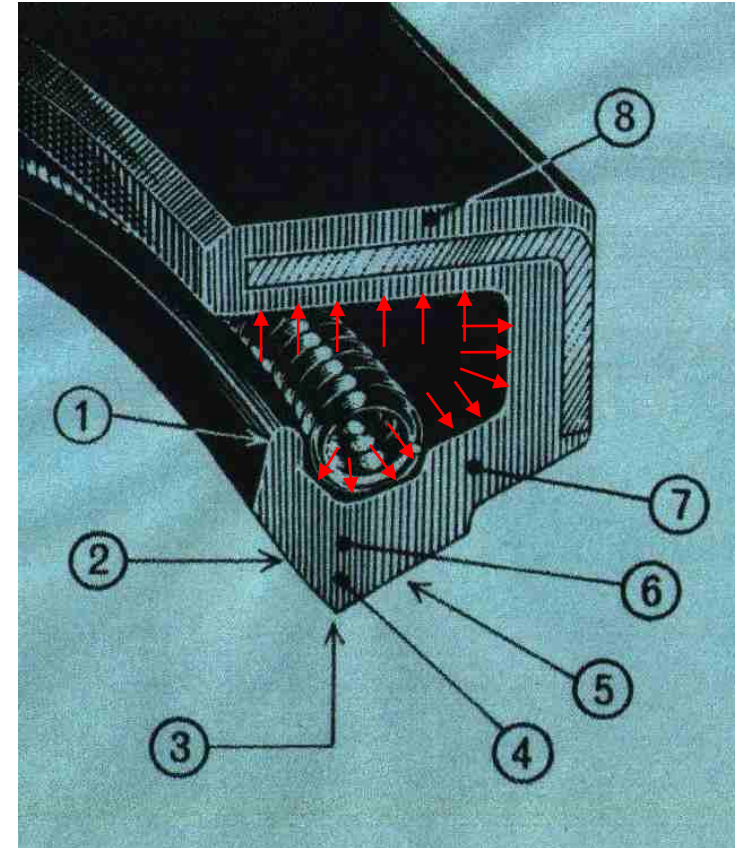

Lip seals - how do they work?

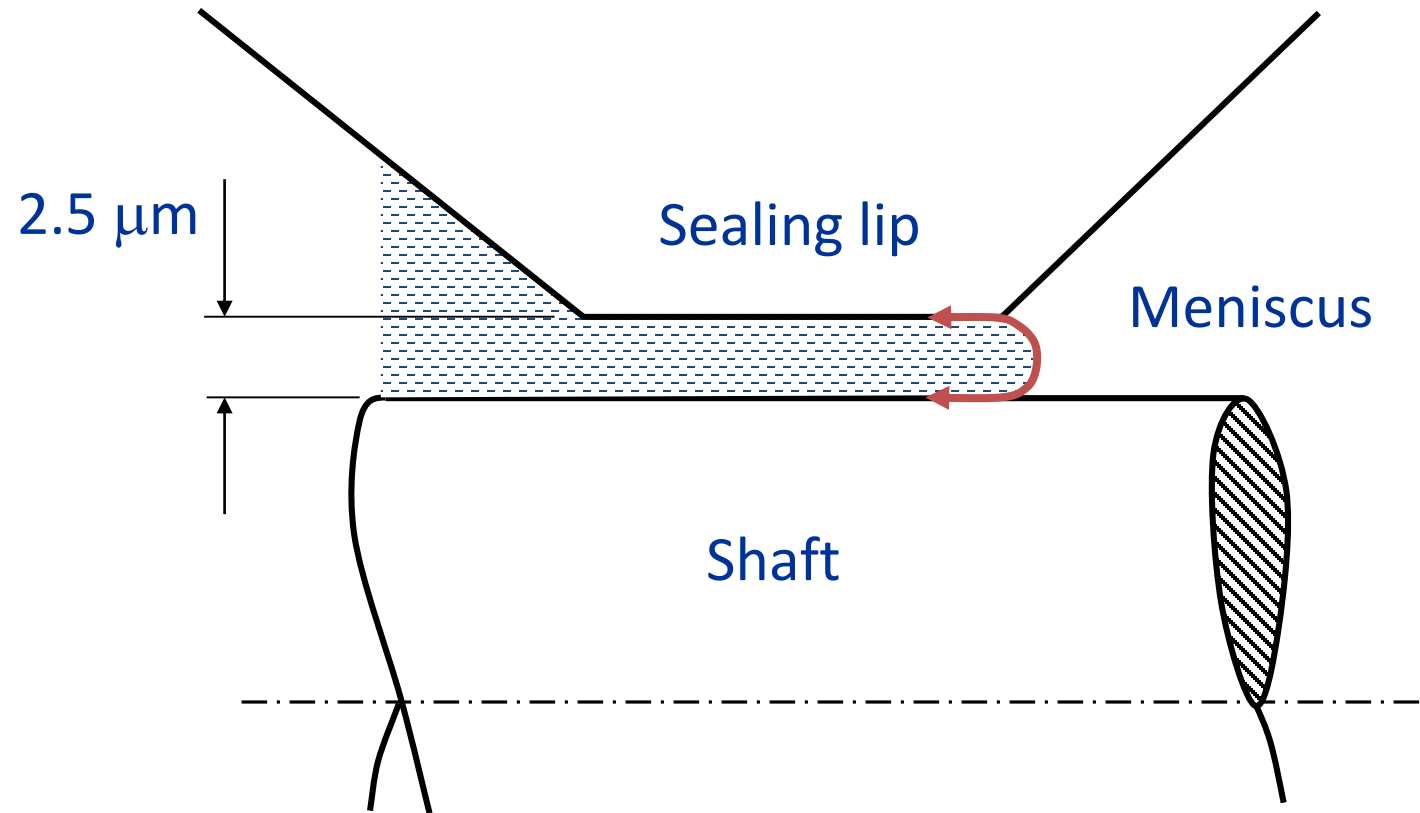

Lip seals - available types

- **BS ISO 6194-1: 2007** defines 4 basic types of rotary shaft lip seals (<https://nusearch.nottingham.ac.uk/>)

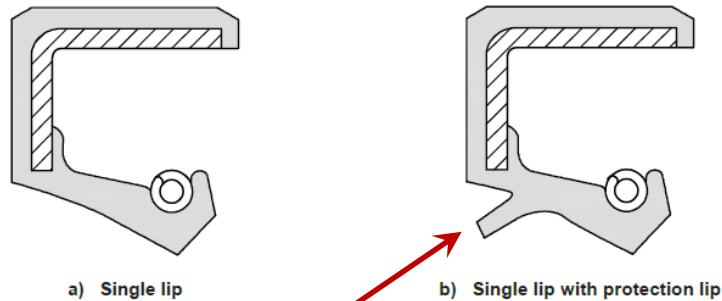
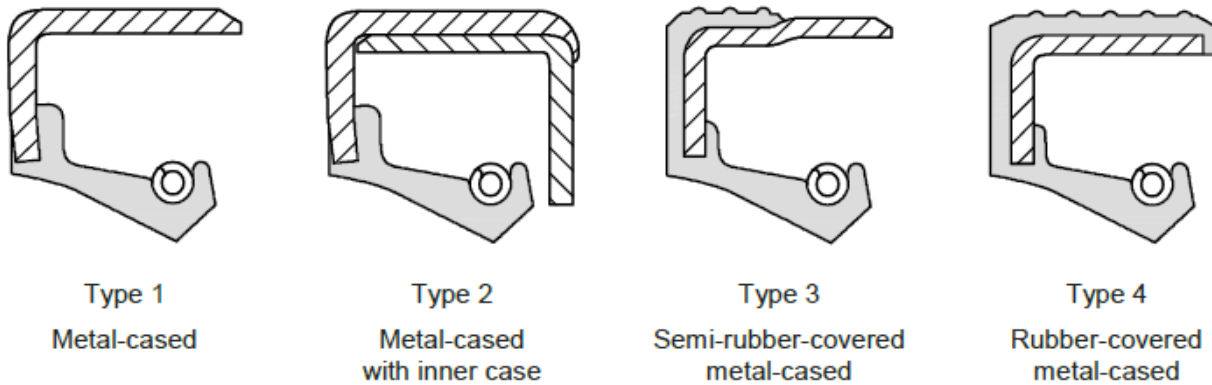

Secondary lip to exclude dirt but can cause temperature to rise

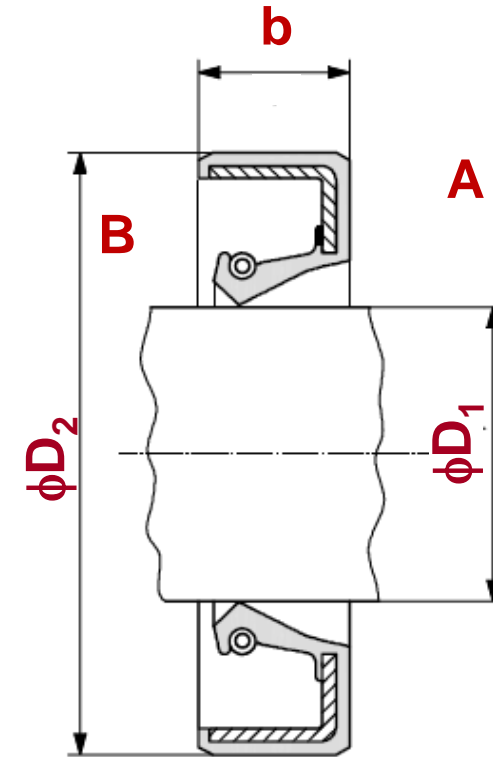

where,

- **D1** nominal dia of shaft
- **D2** nominal dia of housing
- **b** nominal seal width
- **A** Air side
- **B** Fluid side

More variations of radial lip seals

- Radial lip seals for general applications

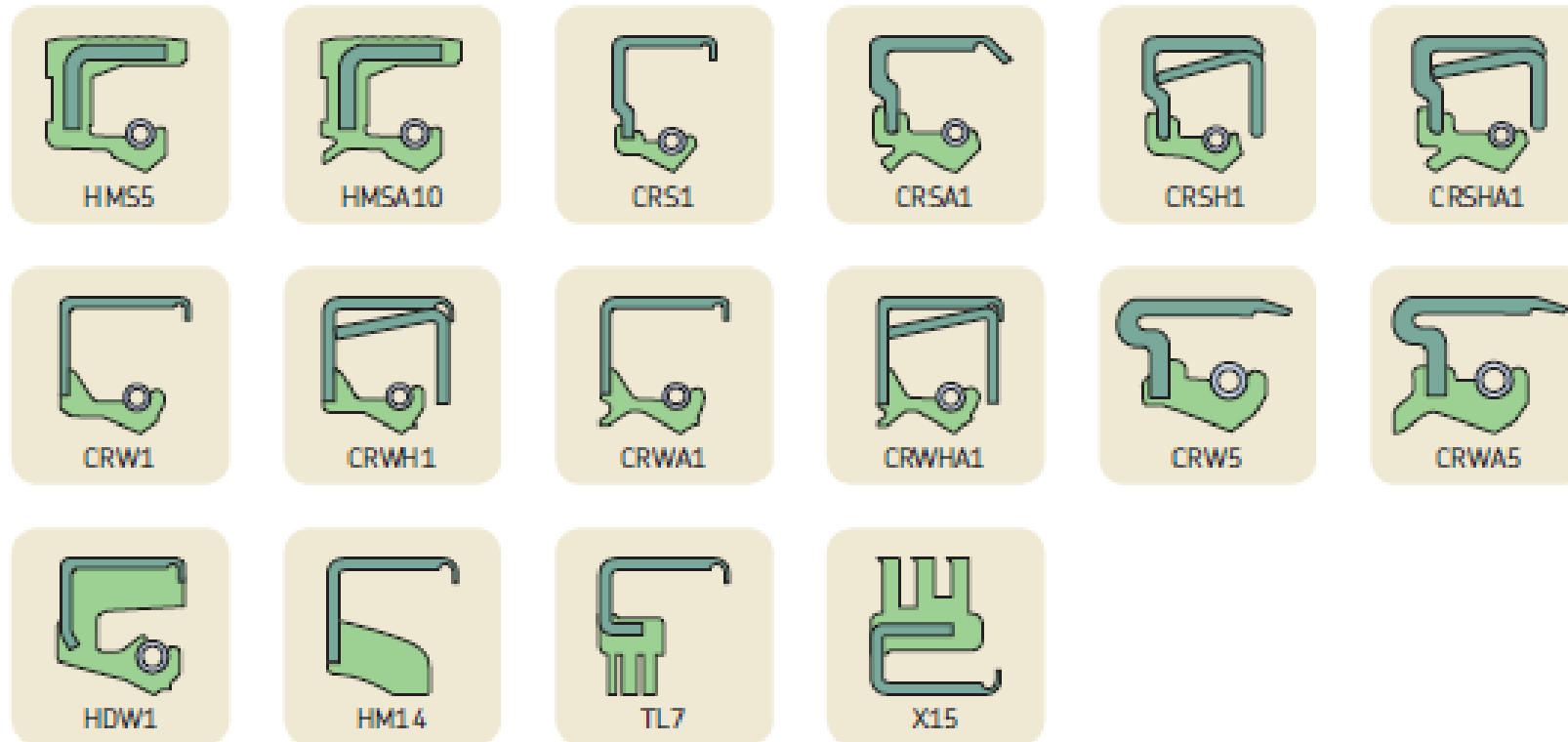

Industrial Shaft Seals documents are available from **SKF website**:

<https://www.skf.com/group/products/industrial-seals/power-transmission-seals>

Or other manufacturers, e.g. **Trelleborg**, [https://www.tss.trelleborg.com/-/media/tss-media-](https://www.tss.trelleborg.com/-/media/tss-media-repository/tss_website/pdf-and-other-literature/catalogs/rotary_gb_en.pdf?revision=876a4291-be84-40af-93fa-fd8bff3925e0)

[repository/tss_website/pdf-and-other-literature/catalogs/rotary_gb_en.pdf?revision=876a4291-be84-40af-93fa-fd8bff3925e0](https://www.tss.trelleborg.com/-/media/tss-media-repository/tss_website/pdf-and-other-literature/catalogs/rotary_gb_en.pdf?revision=876a4291-be84-40af-93fa-fd8bff3925e0)

Methods of Seals Mounting

- Use of radial lip seals and mounting of bearings & seals

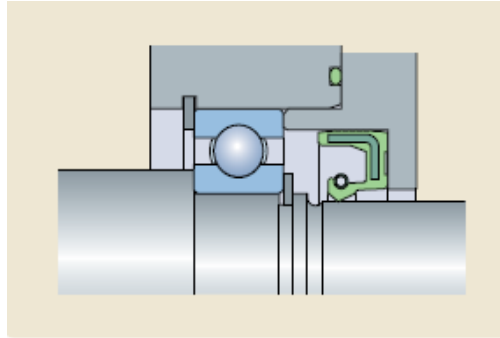

a) SKF HMS5 Radial Seals

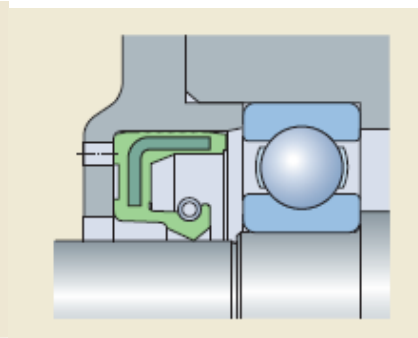

b) SKF HMSA10 radial lip seal

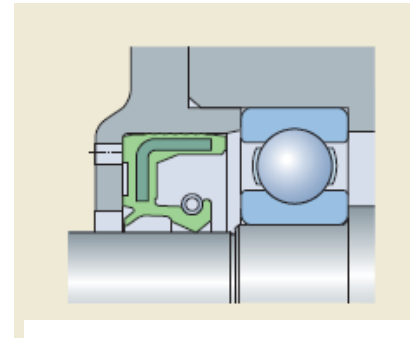

c) SKF V-seal

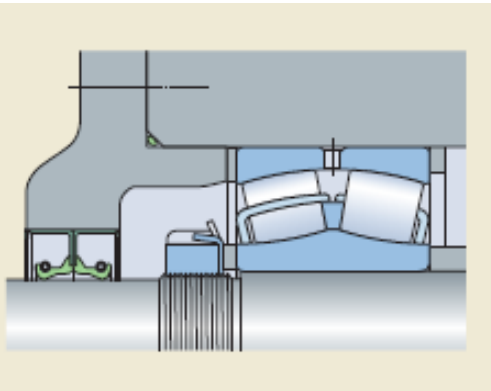
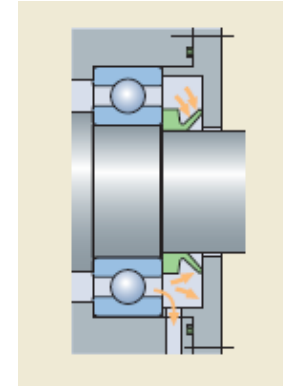

d) SKF radial lip seals in opposite directions

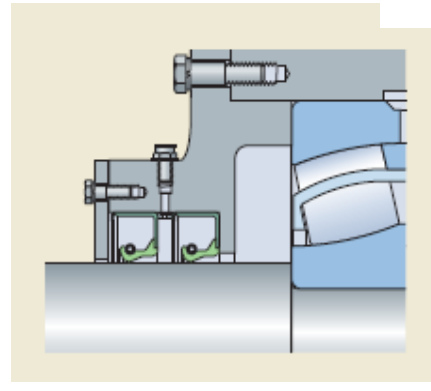

e) SKF CRW1 radial lip seals in tandem

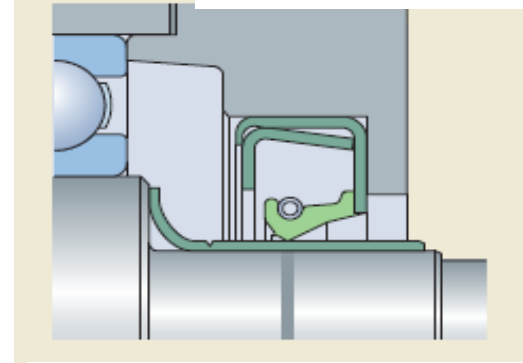

f) SKF radial lip seal with special wear sleeve

Industrial Shaft Seals documents are available from **SKF website**:

https://www.skf.com/binaries/pub12/Images/0901d1968099986c-Industrial-Shaft-Seals-catalogue_tcm_12-524179.pdf#cid-524179

How can oil seals fail?

- **Deterioration of the metal surface**
 - Lip causes pressure to be exerted on shaft
 - If not lubricated, wear will take place
 - Shaft surface should be hardened (45 Rockwell C) and grinded
 - Surface must be $0.2 \mu\text{m } R_a$ to $0.63 \mu\text{m } R_a$ and $0.8 \mu\text{m } R_{\text{max}}$ to $2.5 \mu\text{m } R_{\text{max}}$
- **Deterioration of seal lip due to:**
 - **Damage during installation**
 - **Dirt particles in service**

Repair

- Once a shaft is worn, it must be regrinded or repaired and the seal replaced
- Sleeving can be a cheaper alternative to regrinding



Avoiding damage during installation

- Assemble seal onto shaft, **then** into bore.
- Special assembly **tools** to slide seal over splines on shaft.
- **Chamfers** on housing and shaft.
- **Clean** installation.

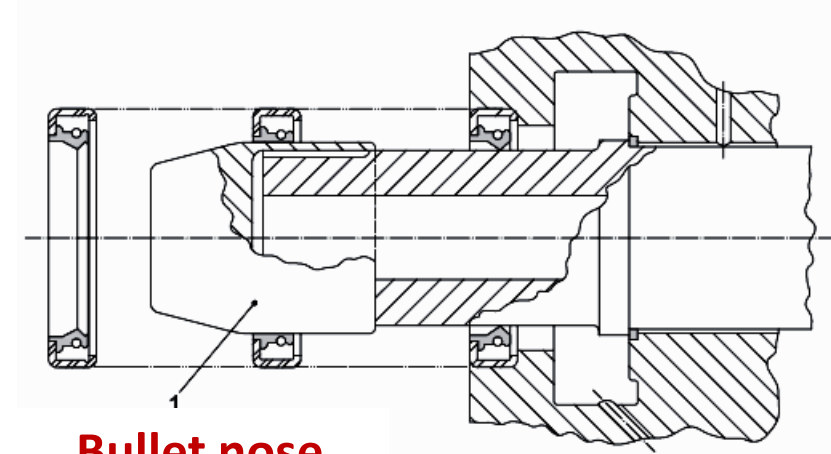

Bullet nose tool

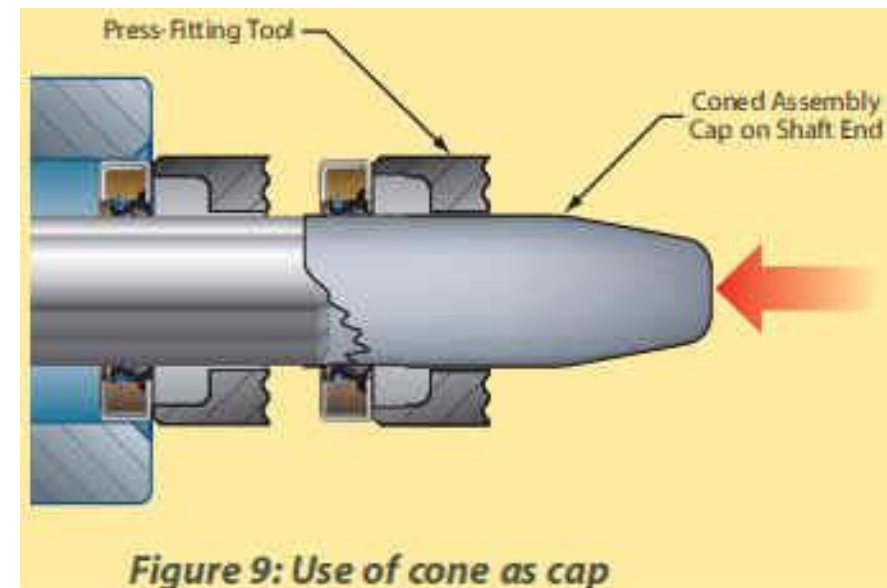
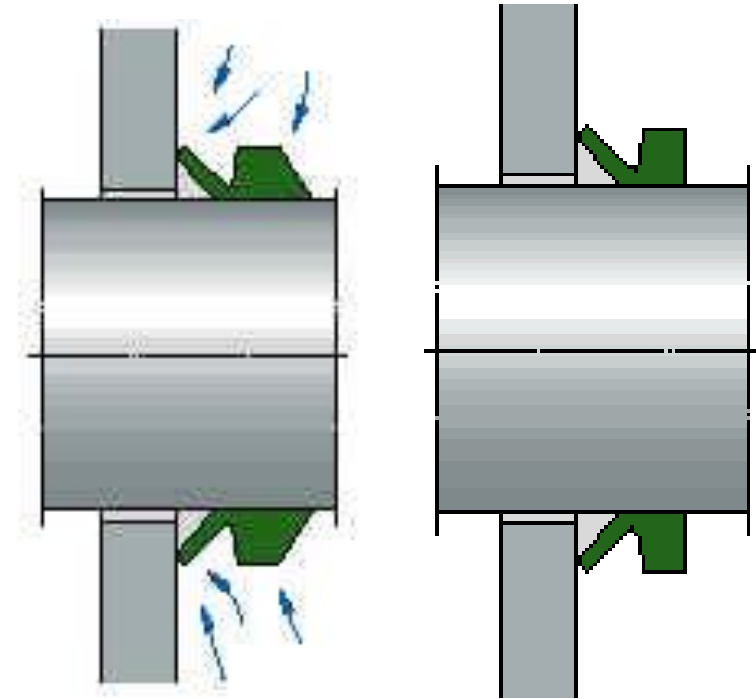

Figure 9: Use of cone as cap

Axial lip (face) seals

- The seal is mounted on the shaft
- The lip runs against a **counterface**
- Better tolerance of eccentricity and out-of-round
- Can withstand **higher pressures**
- **Better tolerance** of abrasion & dirt
- Assembly and axial placement of the seal are trickier



SKF 'V' Seal

<https://www.skf.com/group/products/industrial-seals/power-transmission-seals/v-ring-seals>

Quiz 2: Suitable lubricant and seals for the bevel gearbox

This is the SKF bevel gearbox.

- What are the **suitable means for lubrication** of the **meshing bevel gears** and **bearings** on input and output shafts?
- What **types of seals** are used in the bevel gearbox and **why**?

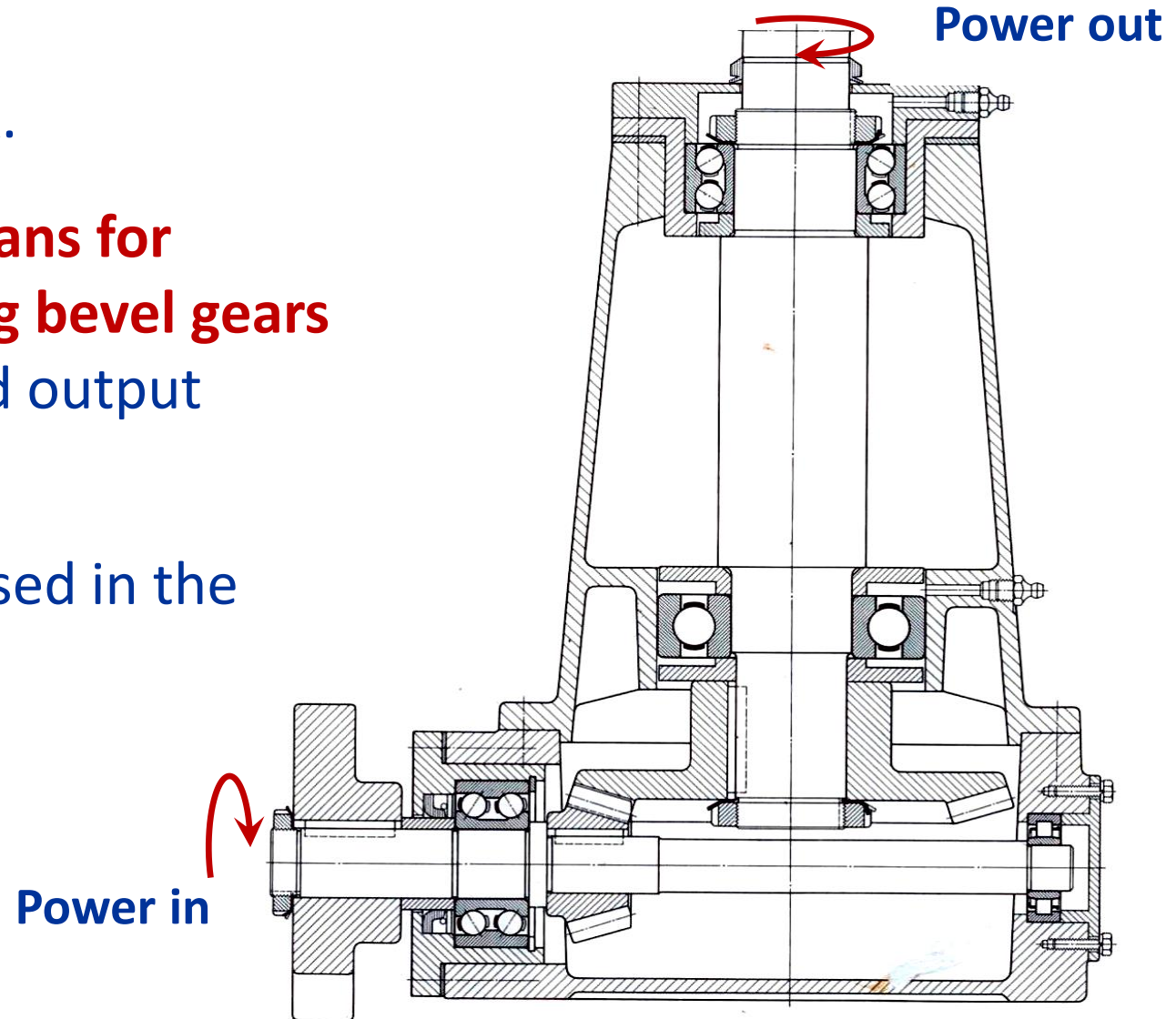

SKF Bevel gear unit

Answer 2: Suitable seals for bevel gearbox

- What type of lubricant is used for **Input** (high speed) shaft?
 - **Oil lubricant** (oil bath) sealed by **Radial lip seal & gasket**
- What type of lubricant is used for **output** (low speed) shaft?
 - **Grease** by **buffer plates & axial lip seals**

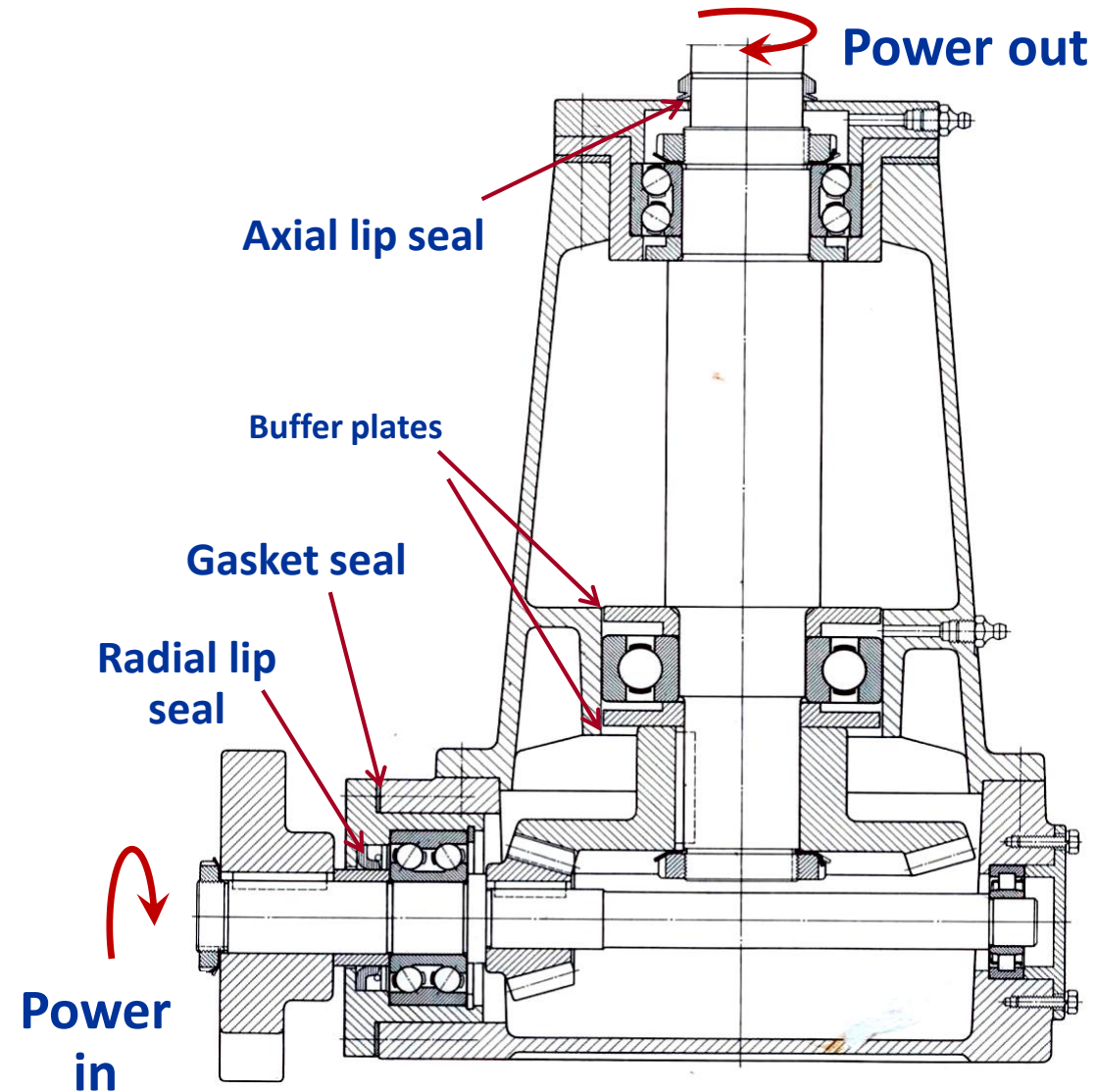

SKF Bevel gear unit

High pressure: higher performance lip seals

- Higher performance can be obtained using PTFE-based lip seals due to its very low friction

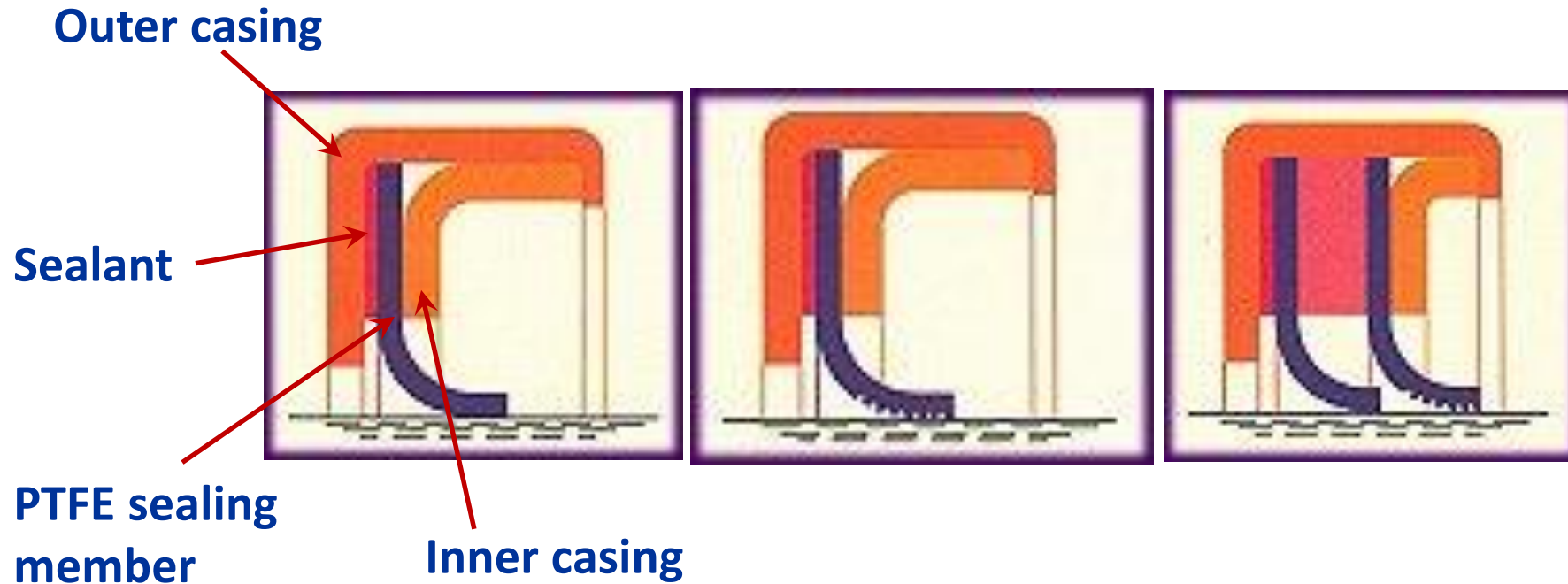

PTFE (Polytetrafluoroethylene) or Teflon commonly used in coating non-sticking pans & cookware

High Pressure: mechanical seals

- **Two sealing rings**, one attached to the rotating shaft & the other to the stationary member
- **Axial springs** provide sealing pressure
- **Carbon ring** running on metal face
- For applications where low leakage, high reliability & low wear are important

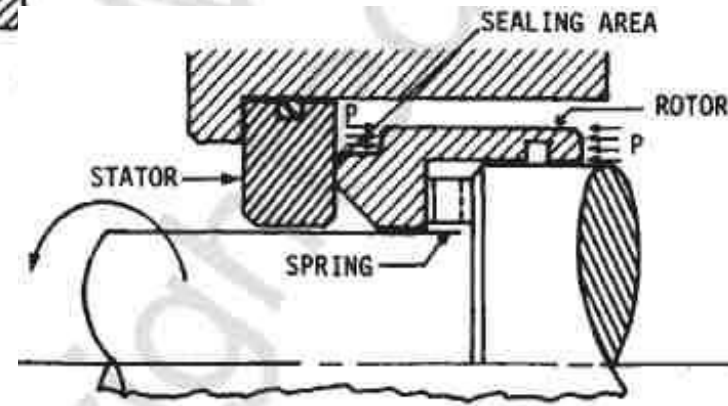
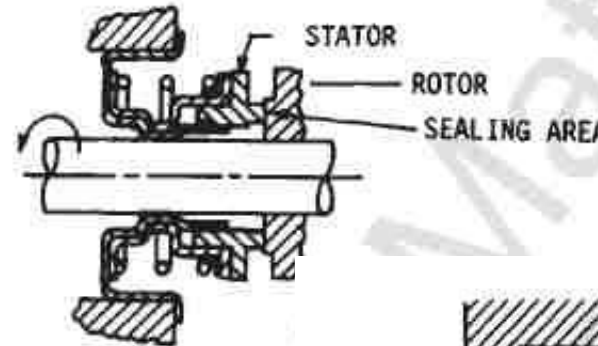

Examples of mechanical seal

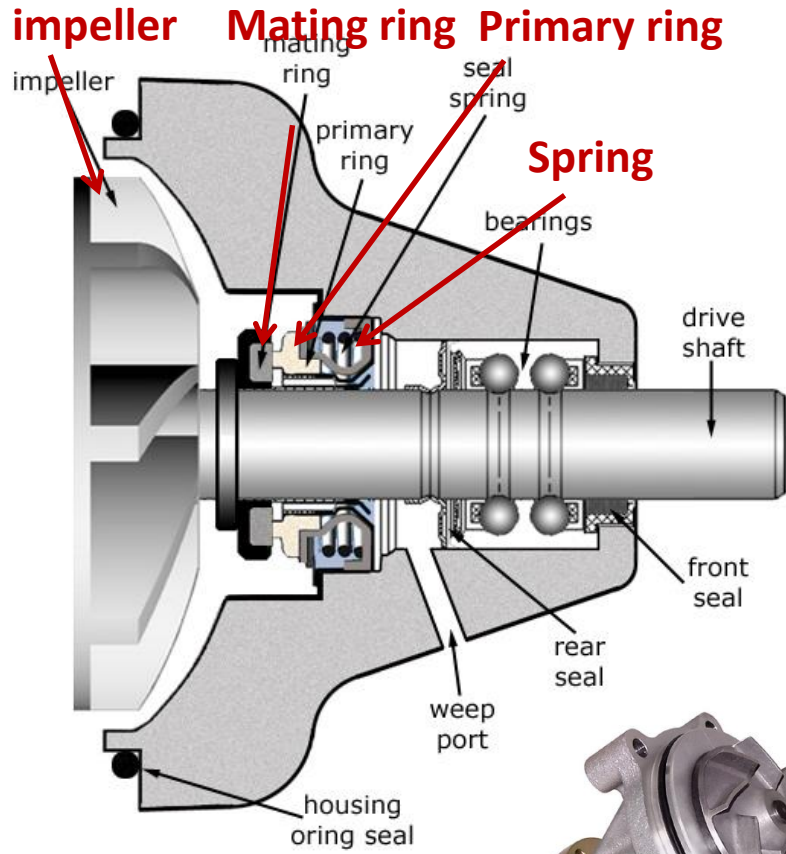

Driving shaft

A car water pump

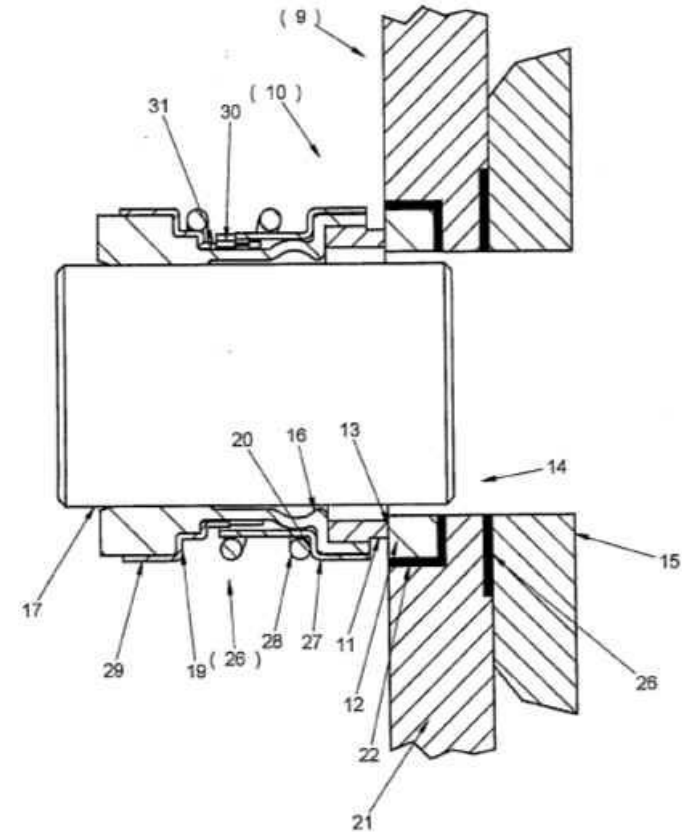
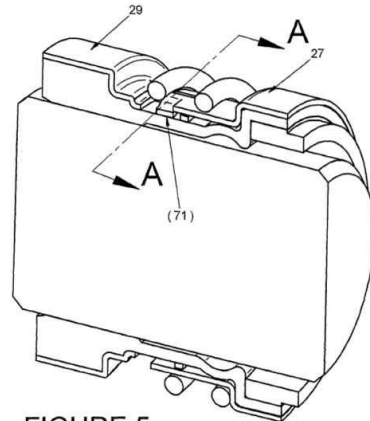

An Int patent by AES Eng, UK,
WO 2007/135402

Hot conditions, high speed:

Labyrinth seals

- **Series of radial fins** forming a restriction to an annular flow of fluid

stationary element

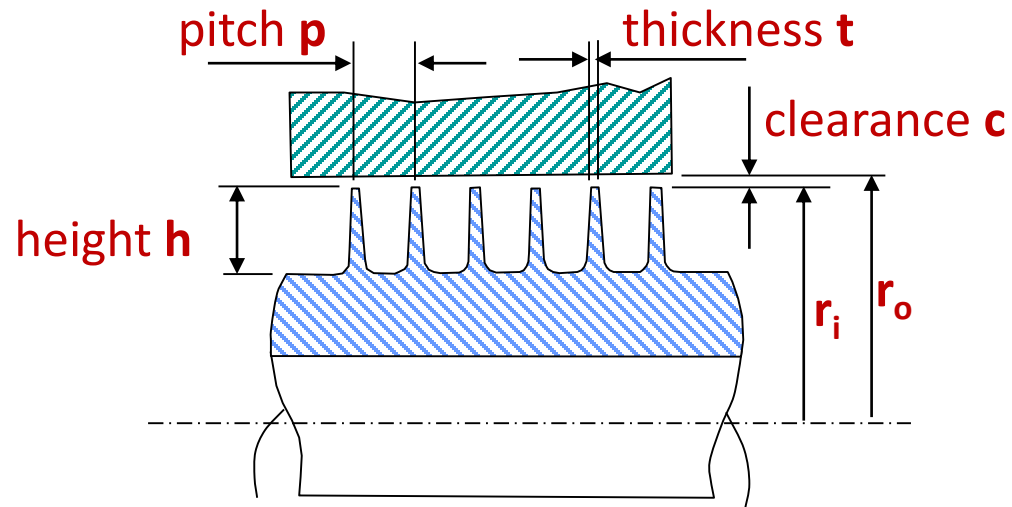

rotating element

Guideline for fin dimensions

| t (mm) | p (mm) | h (mm) |
|-------------|-----------|-----------|
| 0.3 – 0.4 | 6 – 8 | 4 – 5 |
| 0.28 – 0.32 | 4 – 5 | 3 – 3.5 |
| 0.18 – 0.22 | 1.8 – 2.2 | 1.8 – 2.2 |

Flow through labyrinth seals

Mass flow rate equation

$$\dot{m} = A\alpha\gamma\varphi\sqrt{\rho_0 p_0}$$

p_{total}

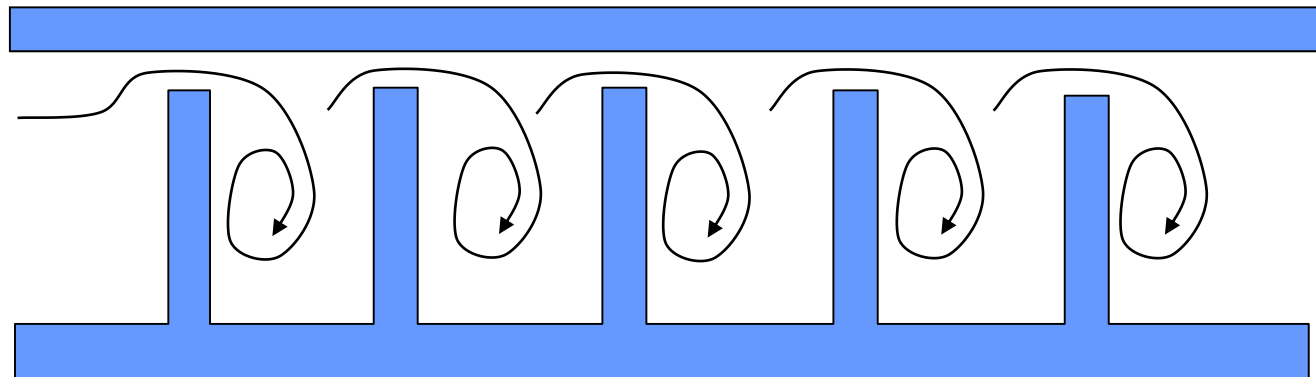
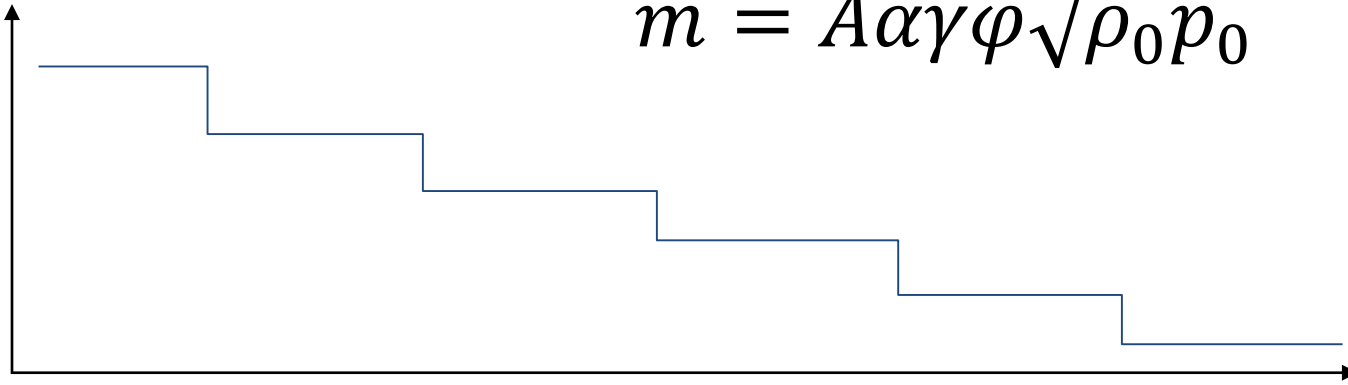

Labyrinth seals

- **Static head** is converted into **dynamic head**
- When narrow gaps open into wide spaces, **dynamic head is lost**
- This creates a series of pressure drops
- **Cannot** provide positive (total) seal
- Will leak if the machine stops
- Used in large machines: **aeroengines, turbines, etc.**

Labyrinth seals in aeroengine applications

- Rolls-Royce Trent 1000 three shaft jet engine

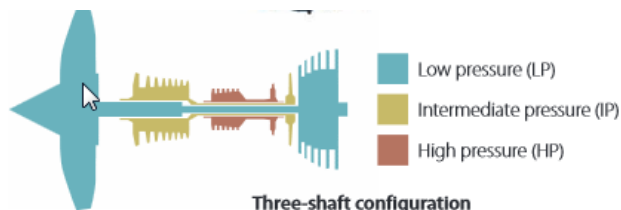
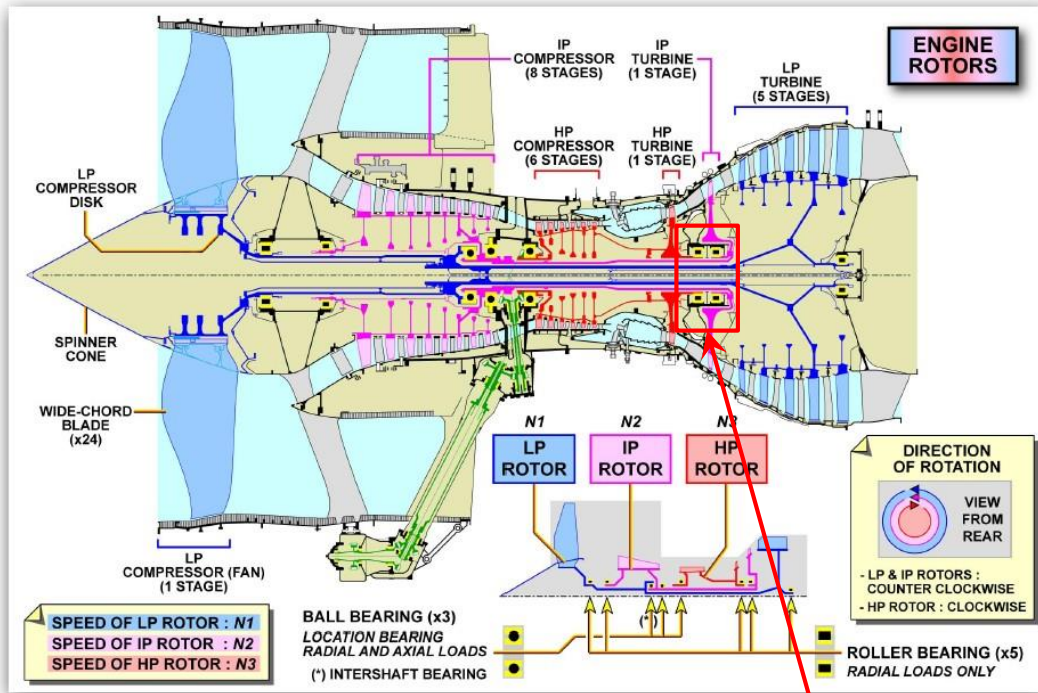

HP-IP bearing chamber

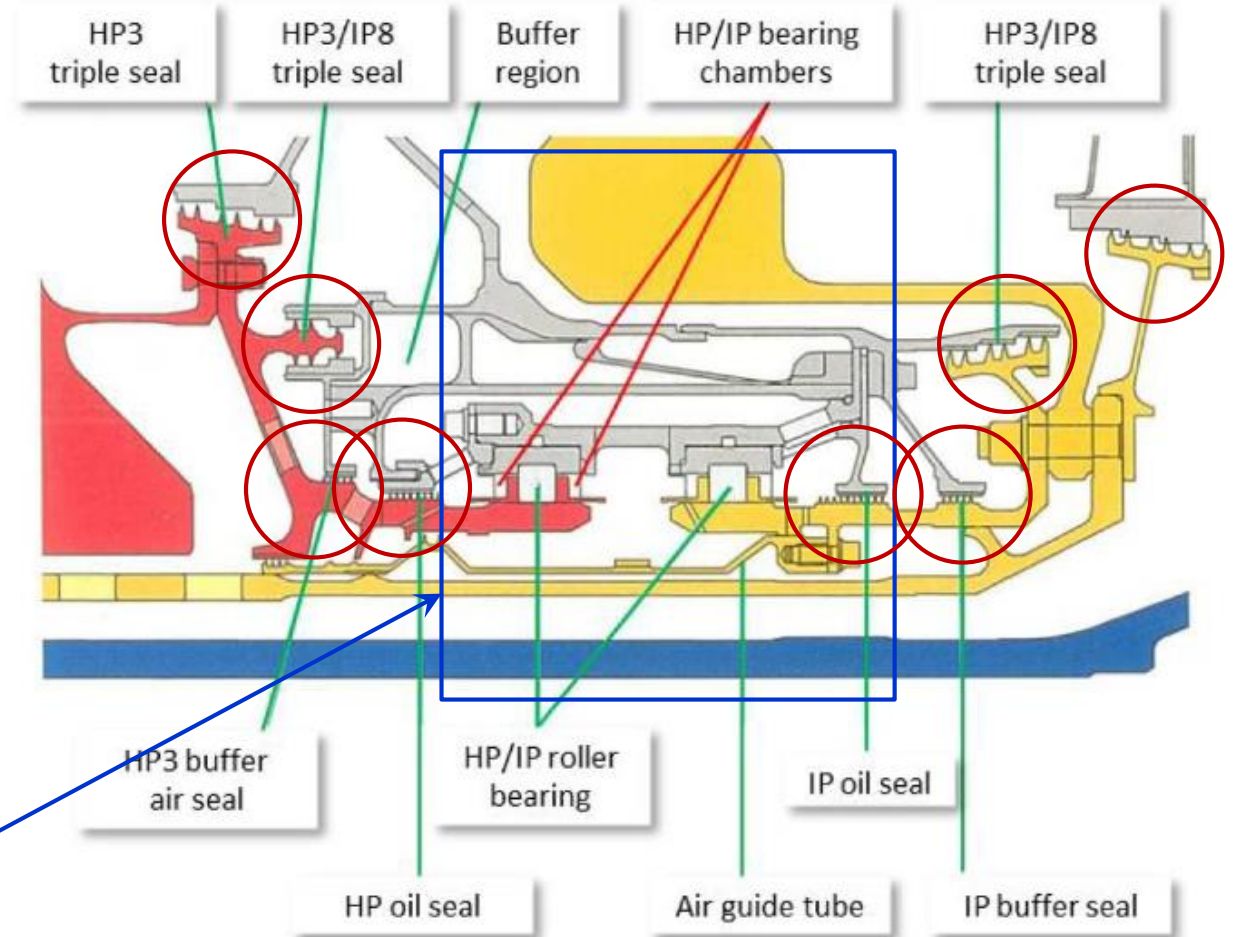

Mass flow rate by Egli (1935)

$$\dot{m} = A\alpha\gamma\varphi\sqrt{\rho_0 p_0}$$

\dot{m} = mass flow rate (kg/s)

$A = \pi(r_o^2 - r_i^2)$ area of gap (m²)

α = flow coefficient =

0.71 for $1.3 < c/t < 2.3$

γ = carry over correction factor

φ = expansion ratio

$$\varphi = \sqrt{\frac{1 - (p_n/p_o)^2}{n - \ln(p_o/p_n)}}$$

ρ_0 = density at the upstream condition (kg/m³)

p_o = upstream pressure (Pa)

p_n = downstream pressure (Pa)

| Carryover correction factor | No. of fins n |
|---------------------------------------------|-----------------|
| $\gamma = 1 + 3.27 (c/p)$ | 2 |
| $\gamma = 1 + 5 (c/p)$ | 3 |
| $\gamma = 1 + 6.73 (c/p)$ | 4 |
| $\gamma = 1 + 8.82 (c/p)$ | 6 |
| $\gamma = 1 + 10.2 (c/p)$ | 8 |
| $\gamma = 1 + 11.2 (c/p)$ | 12 |
| c – radial clearance (m), p – pitch (m) | |

The compromise

Selection of a seal type depends on fluid pressure, shaft speed & level of sealing

Level of seal vs wear/friction/longevity

| Type of seals | Working condition | Level of seal | Longevity |
|-----------------------------------------|---------------------------------------------------------------------------------|--------------------|---------------|
| 'O' rings | Low pressure & low temperature & low speed High friction | Negligible leakage | Short life |
| Lip seals & mechanical seals | Low/high pressure & low/high temperature & moderate/high speed Some friction | Slight leakage | Moderate life |
| Labyrinth seals | High temperature & high speed No friction | High leakage | Long life |

Worked example 2: Selection of a radial lip seal

Select a **radial lip seal** for a shaft sub-assembly. Shaft dia is $\phi d_1 = \phi 25$ mm, housing dia is $\phi D = \sim \phi 40$ mm and housing width is $b = 5 \sim 7$ mm.

Note: Shaft dia (ϕd_1) is normally determined by the required torque capability. The sizes, such as the **housing dia** (ϕD) and **width** (b) may vary based on other considerations.

From **SKF website** at <https://www.skf.com/uk/products/industrial-seals>, a suitable radial lip seal may be chosen.

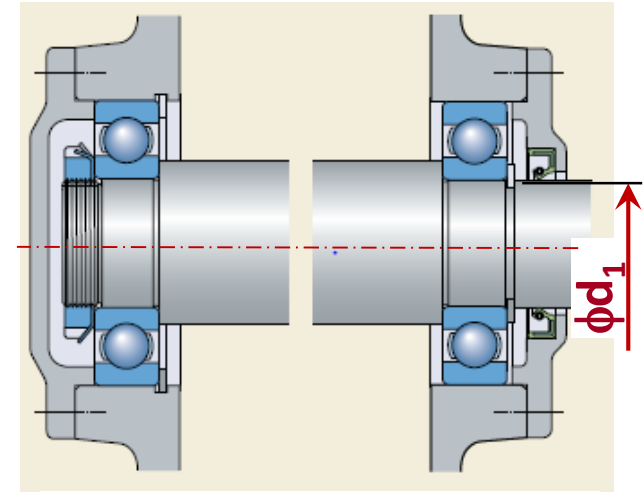

A shaft sub-assembly

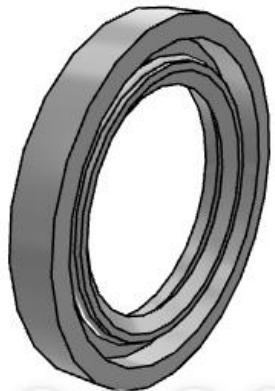

- **HMS5 25x40x5RG** or **HMS5 25x40x7RG** may be chosen for this application.
- A CAD model may also be download from the website

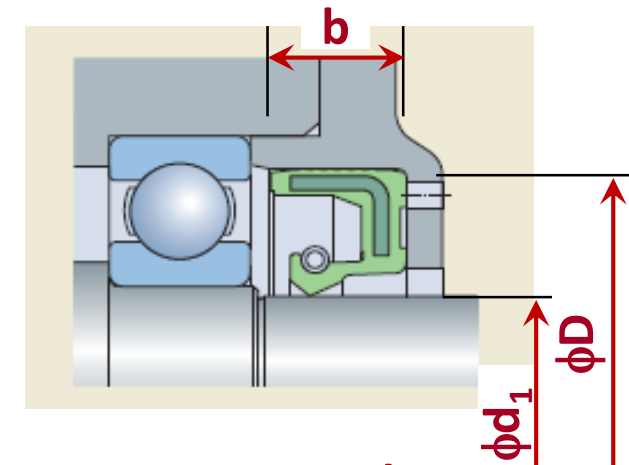

SKF HMS5 seal





University of
Nottingham

UK | CHINA | MALAYSIA

Seals

End of Part 2



University of
Nottingham

UK | CHINA | MALAYSIA

Seals

Part 3

Sealing **reciprocating** shafts

- High **temperature**, high speed
 - Piston rings
- High **temperature**, low speed
 - Stuffing box
- Low **temperature**/Hydraulic
 - **'O' rings**
 - **Lip seals/packings: 'U', 'V' and cup**

High temperature and speed: piston rings

- **Piston rings** are usually machined from a **fine grain alloy cast iron** and must be **split** to assembly over the piston
- Spring of the rings keeps them in contact with the cylinder



High temperature and speed: piston rings

Performance is largely dependent on a **high surface finish** on both bore & rubbing surface of the rings

Piston rings wear to
A parabolic profile

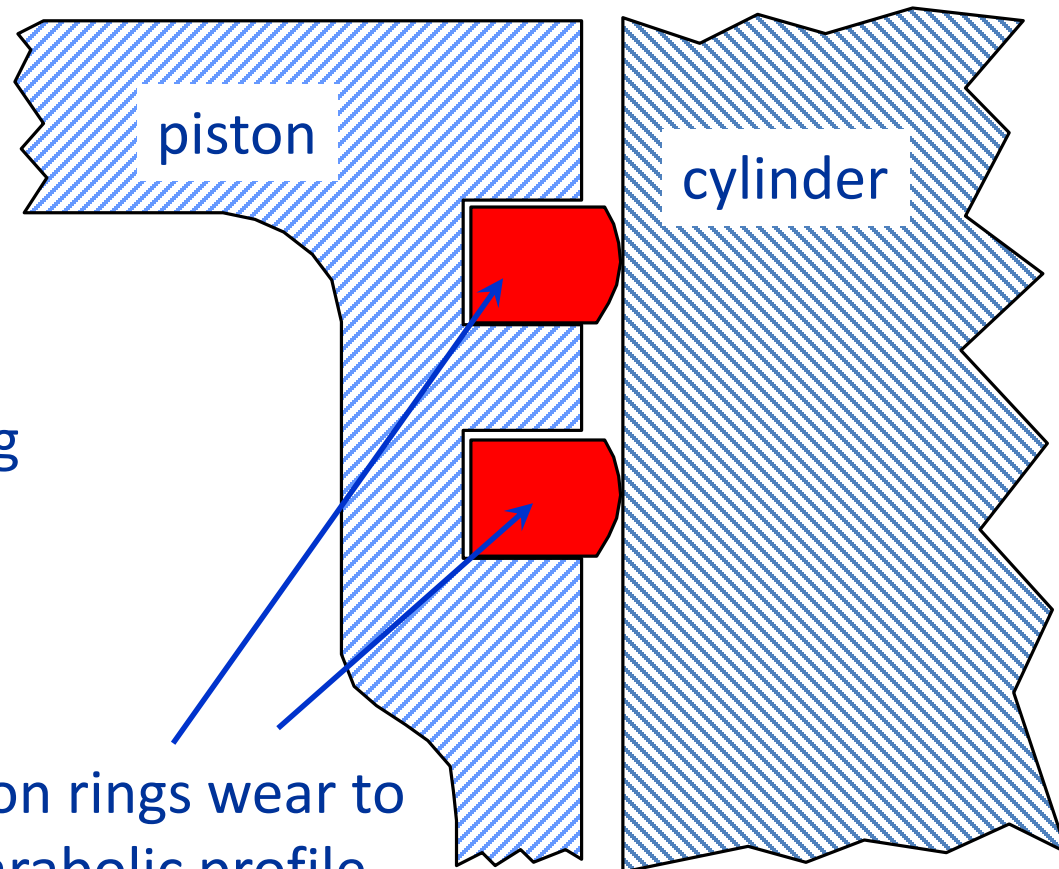

High temperature and speed: piston rings

Number of rings with a given pressure

| p_0 (bar) | No. of rings |
|-------------------|--------------|
| <20 | 2 |
| $20 < p_0 < 60$ | 3 |
| $60 < p_0 < 100$ | 4 |
| $100 < p_0 < 200$ | 5 |
| >200 | 6+ |

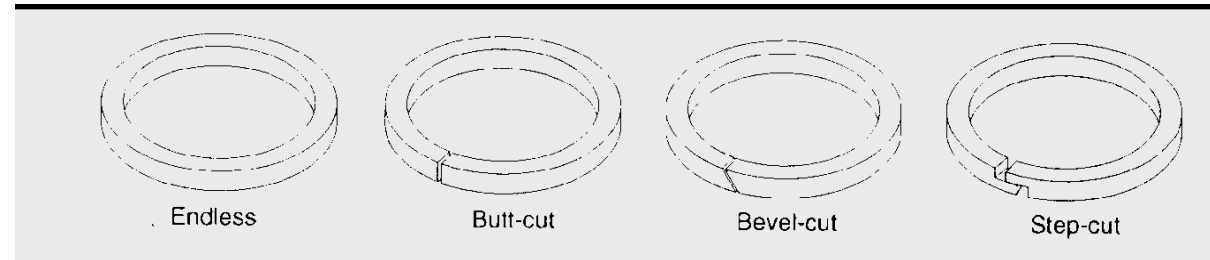

Piston rings

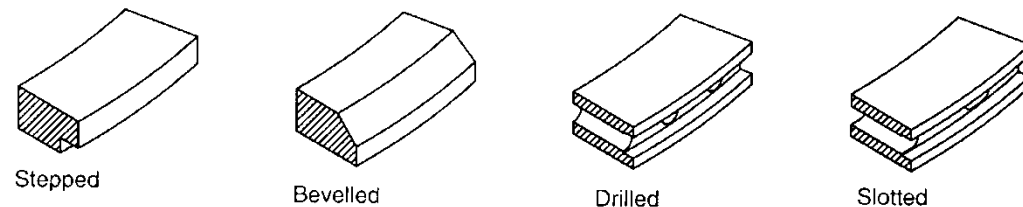
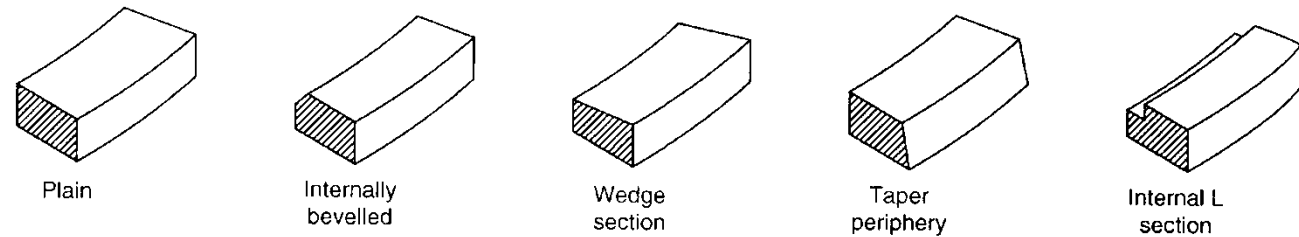

Piston ring sections

BS 5341-7.1.1:1992

Piston rings for IC Engines

High temperature, low speed: stuffing box

- **Packing** is compressed within housing
- Creates pressure between packing & shaft
- **Leather, solid rubber or fabric-reinforced rubber** may be used as packing materials

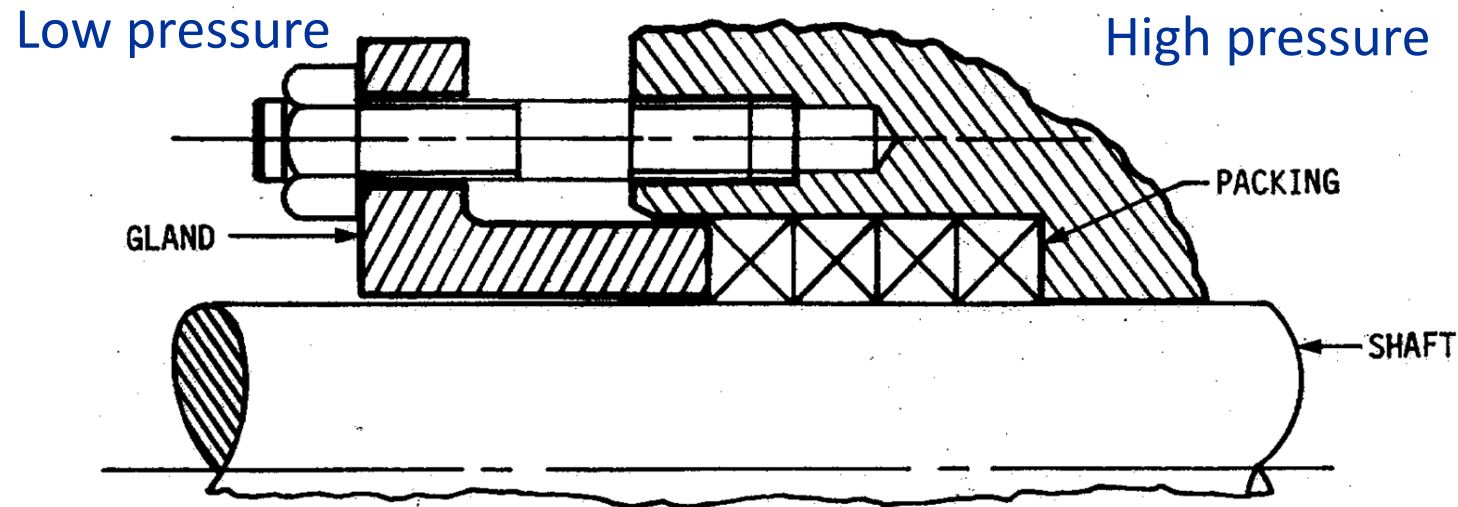

Packing types

- Various types of packing are available allowing variations in:
 - chemical resistance
 - temperature resistance
 - frictional characteristics
 - longevity
 - lubricant-carrying capacity
 - sealing capability
- Packings are spiral wound into the gap



Rolled

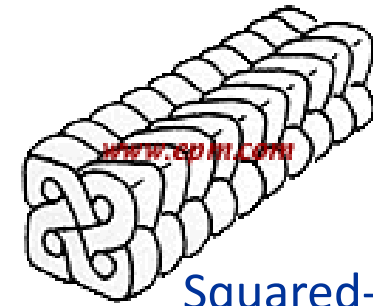

Squared-braid



Multi-braid



Twisted

Stuffing box: often packed with chevron-section or 'V' packing rings

- 'V' packing is mainly used for sealing piston rods and reciprocated shafts for high pressure conditions

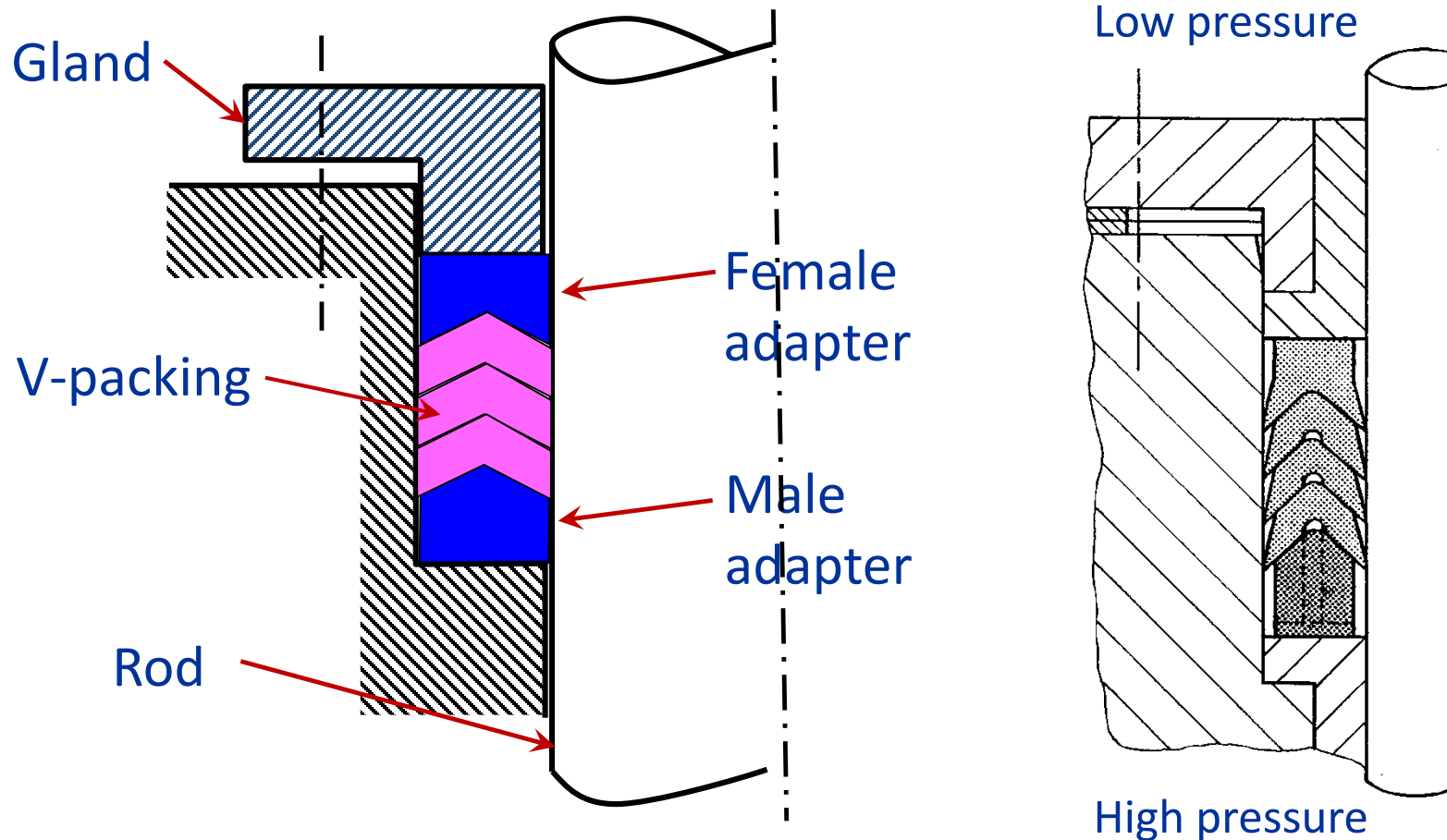

Cold conditions, slow movement

– e.g. hydraulic & pneumatic

- 'O' rings, 'U' & Cup packings may be used;

'U' rings

- Provides sealing for pistons or piston rods (in one direction only)
- When pressure is applied:
 - one lip is forced against stationary member
 - other is forced against moving member
- Similar pressure range as 'O' rings and backup rings used for higher pressure

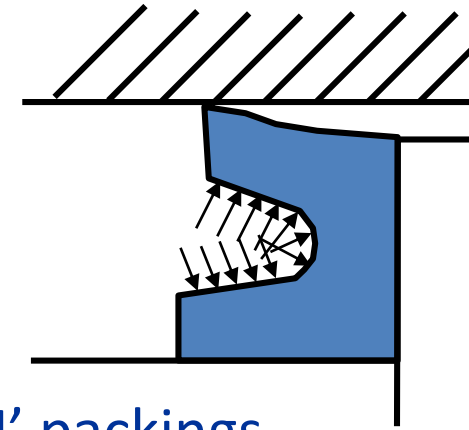

'U' packings

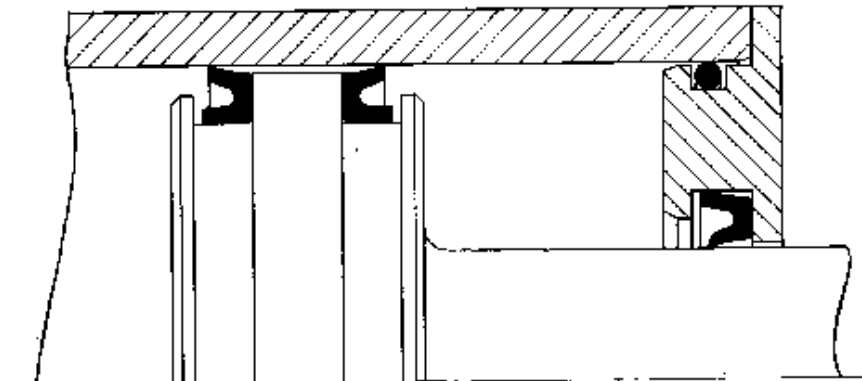

Cold conditions, slow movement

– e.g. hydraulic & pneumatic

Cup packing

- Cup packing has dynamic seal with cylinder but static seal with piston
- It is uni-directional seal so two cups back to back for double-acting piston seals

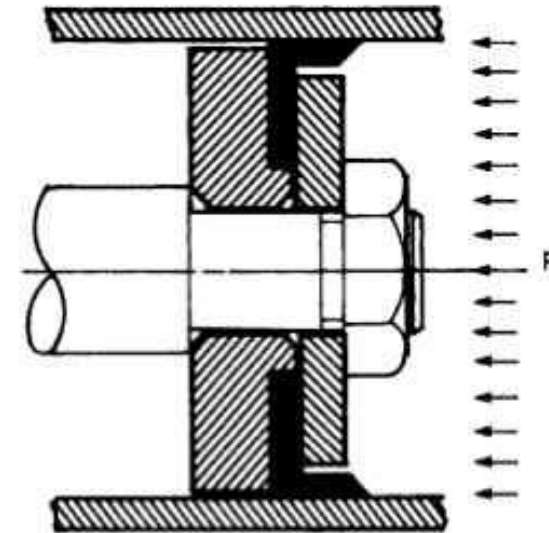
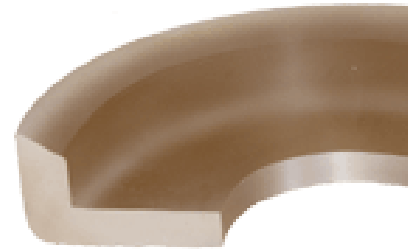
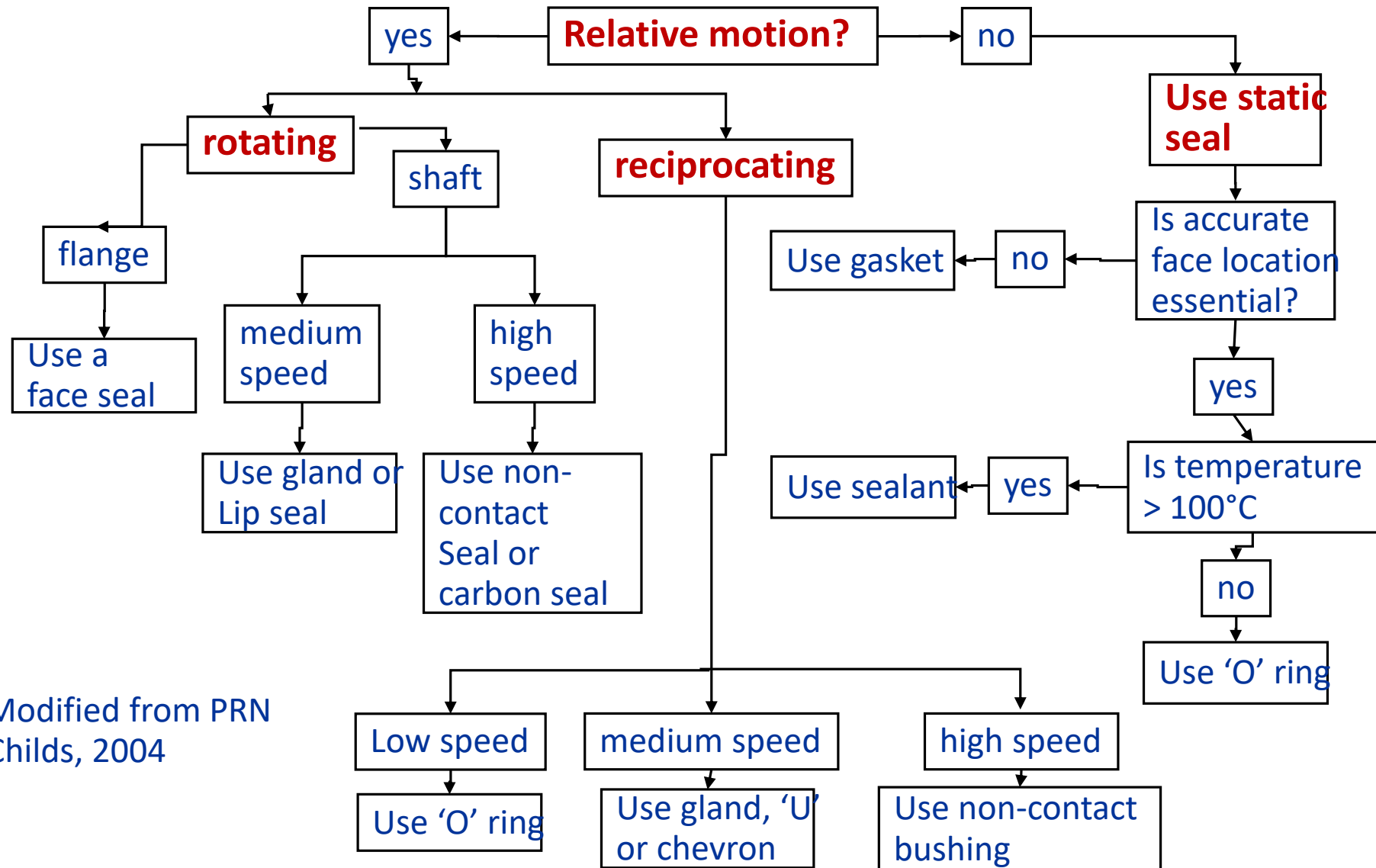

FIGURE 21.14 Cup packing for single-acting cylinder.

“U” rings and cup packing

- Working ranges:
 - Cup packing up to 35 bar
 - “U” packing up to 100 bar
 - “U” packing with metal insert up to 250 bar
 - With close working clearances up to 400 bar
 - Operating speeds 0 - 25 m/s
- “U” rings for higher pressures
 - Made of harder materials than rubber
 - Nylon
 - Polyurethane
 - PTFE
 - Glass-filled
 - Typically have a **spring insert** for ‘pre-energisation’

Seal Selection



Modified from PRN
Childs, 2004

Limits of pressure and speed

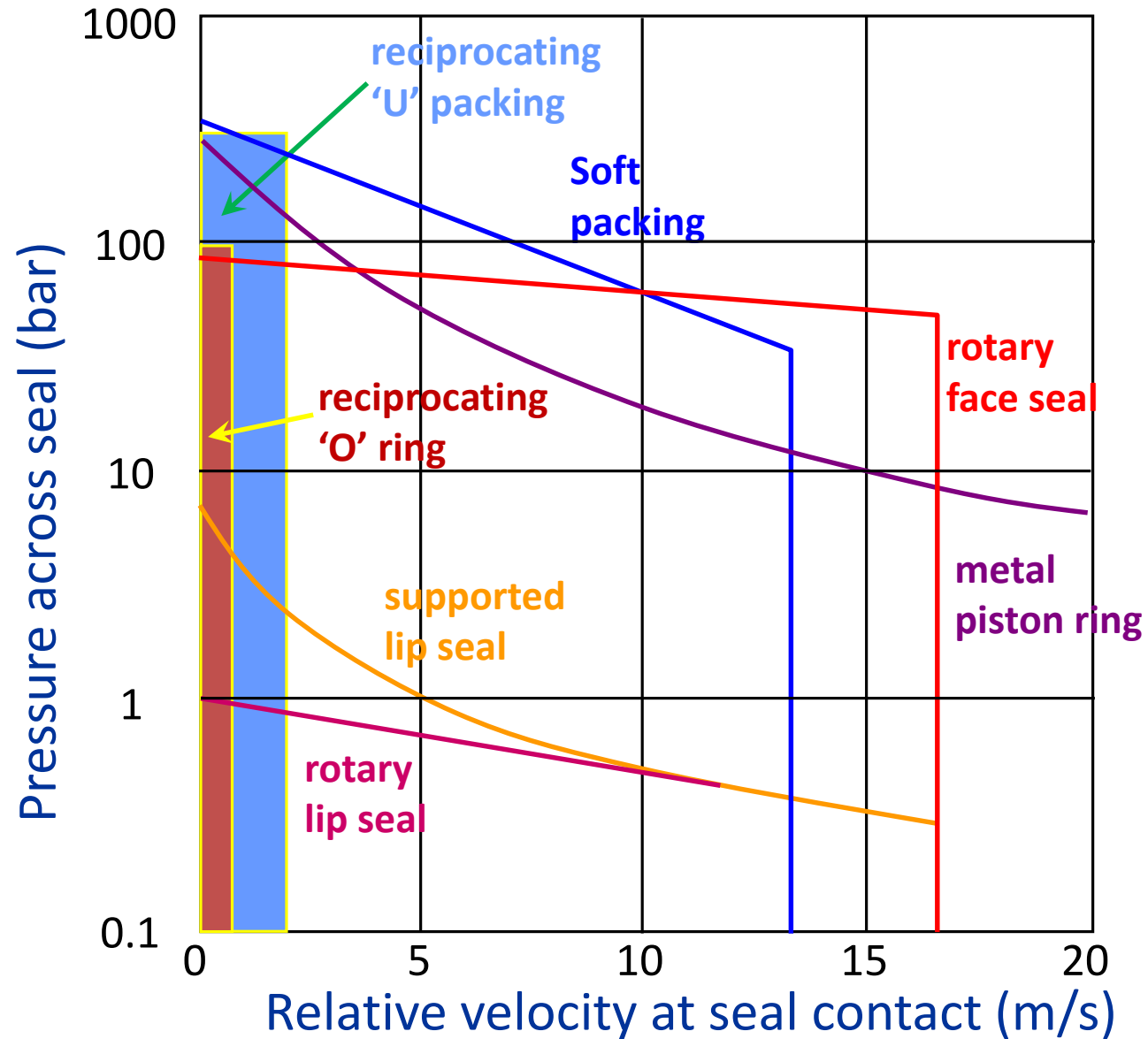

Quiz 3: True or False to each of the following statements in seal selection

- A. **“O” rings** may be used as a means of sealing a machine of **rotating and reciprocating motions**.
- B. Extrusion is a form of **“O” ring** failure due to incorrect installation.
- C. **Radial lip seals** are commonly used in machines at low speed and low temperature, e.g. gearbox in wind turbine.
- D. Gasket seals made of different types of polymeric materials are commonly used for static applications.
- E. A **labyrinth seal** can provide **total seal** of a high speed turbine machine.

Quiz 3: **True or False** to each of the following statements in **seal selection**

- A. **“O” rings** may be used as a means of sealing a machine of **rotating and reciprocating motions**. (true)
- B. Extrusion is a form of **“O” ring** failure due to incorrect installation. (false)
- C. **Radial lip seals** are commonly used in machines at low speed and low temperature, e.g. gearbox in wind turbine. (true)
- D. Gasket seals made of different types of polymeric materials are commonly used for static applications. (true)
- E. A **labyrinth seal** can provide **total seal** of a high speed turbine machine. (false)

Summary

- Understanding of “O” ring, radial and face lip seals and their general operation conditions;
- Selection of an “O” ring or radial lip seal for static and rotating conditions;
- Use of Seal manufacturers, e.g. SKF, Trelleborg or James Walker website and BS standard for the selection of “O” ring and radial lip seals.

Revision Questions

- a) How are **seals** classified based on the forms of motion?
- b) What are **basic approaches** of different types of seals to prevent or limit leakage of a machine system?
- c) How is a **BS 4518:1982 “O” ring** codified to define its dimensions?
- d) Do you know the common forms of **“O” ring failure** and ways for failure prevention?
- e) Can you use BS 4518:1982 to **choose an “O” ring and define appropriate groove dimensions?**
- f) Can you name a few **seal types for rotating shafts at various working conditions?**
- g) Can you use a manufacturer’s catalogue, e.g. by SKF or Trelleborg to **select a radial lip seal** for gearbox in an electric car, Nissan Leaf?
- h) How do you **evaluate the level of performance of labyrinth seals** for high speed and high temperature application, e.g. aeroengine shaft?

References

- <http://www.marcorubber.com/>
- http://www.jameswalker.biz/product_range/41--O-ring-all-stocked-ranges
- http://de.dichtomatik.com/en/produktkatalog/o_ringe/
 - Online “O” ring catalogue and selection guidelines
- <https://www.skf.com/group/products/industrial-seals/power-transmission-seals>
- https://www.skf.com/binaries/pub12/Images/0901d1968099986c-Industrial-Shaft-Seals-catalogue_tcm_12-524179.pdf#cid-524179
- <https://www.tss.trelleborg.com/global/en/homepage/homepage.html>
- https://www.tss.trelleborg.com/-/media/tss-media-repository/tss_website/pdf-and-other-literature/catalogs/rotary_gb_en.pdf?revision=876a4291-be84-40af-93fa-fd8bff3925e0
 - Online Radial lip seal catalogue and selection guidelines
- BS 4518:1982: Metric dimensions of O-ring and housing
- **BS ISO 3601-1 to 5: O-Rings for fluid power systems**
- BS 5106:1988: Specifications of spiral backup rings
- Childs, R.N., 2004. Mechanical Design, Elsevier
- Shigley, J.E. and Mischke, C.R. (Eds.), 2004. *Standard Handbook of Machine Design*, McGraw-Hill, Chapter 26



**University of
Nottingham**

UK | CHINA | MALAYSIA

Seals

End of Session